



# **AERONAUTICAL TELECOMMUNICATIONS**

## **LEBAENESE AVIATION REGULATIONS LARS VIII**

### **SUBPART 804 (SURVEILLANCE RADAR AND COLLISION AVOIDANCE SYSTEM)**

**FIRST EDITION OF SUBPART 804 – JULY 2007**

# **SUBPART 804 – SURVEILLANCE RADAR AND COLLISION AVOIDANCE SYSTEM**

## **CONTENTS**

804.1	<b>DEFINITIONS</b>	Page 2
804.2	<b>GENERAL</b>	Page 2
804.2.1	Secondary Surveillance Radar (SSR)	Page 2
804.2.2	Human Factors considerations	Page 6
804.3	<b>SURVEILLANCE RADAR SYSTEMS</b>	Page 7
804.3.1	Secondary Surveillance Radar (SSR) System Characteristics	Page 7
804.3.1.1	System having only Mode A and Mode C capabilities	Page 7
804.3.1.2	System having Mode S capabilities	Page 13
804.4	<b>AIRBORNE COLLISION AVOIDANCE SYSTEM</b>	Page 77
804.4.1	Definitions related to Airborne Collision Avoidance System	Page 77
804.4.2	ACAS I General Provision and Characteristics	Page 79
804.4.3	General Provision relating to ACAS II and ACAS III	Page 81
804.4.4	Performance of the ACAS II Collision Avoidance Logic	Page 106
804.4.5	ACAS Use of Extended Squitter Reports	Page 121

## SUBPARTS 804 - SURVEILLANCE RADAR AND COLLISION AVOIDANCE SYSTEMS

Part VIII of the Lebanese Aviation Regulations is issued by the Lebanese Civil Aviation Authority (LCAA) in pursuit of its obligations to ensure compliance to ICAO requirements of accepted international regulations and standards at aerodromes in Lebanon and to follow up their execution.

### 804.1 DEFINITIONS

**Airborne collision avoidance system (ACAS).** An aircraft system based on secondary surveillance radar (SSR) transponder signals which operates independently of ground-based equipment to provide advice to the pilot on potential conflicting aircraft that are equipped with SSR transponders.

**Aircraft address.** A unique combination of twenty-four bits available for assignment to an aircraft for the purpose of airground communications, navigation and surveillance.

**Collision avoidance logic.** The sub-system or part of ACAS that analyses data relating to an intruder and own aircraft, decides whether or not advisories are appropriate and, if so, generates the advisories. It includes the following functions: range and altitude tracking, threat detection and RA generation. It excludes surveillance.

**Human Factors principles.** Principles which apply to aeronautical design, certification, training, operations and maintenance and which seek safe interface between the human and other system components by proper consideration to human performance.

**Secondary surveillance radar (SSR).** A surveillance radar system which uses transmitters/receivers (interrogators) and transponders.

**Surveillance radar.** Radar equipment used to determine the position of an aircraft in range and azimuth.

### 804.2 GENERAL

#### 804.2.1 SECONDARY SURVEILLANCE RADAR (SSR)

804.2.1.1 When SSR is installed and maintained in operation as an aid to air traffic services, it shall conform with the provisions of 804.3.1 unless otherwise specified in this 804.2.1.

#### 804.2.1.2 Interrogation modes (ground-to-air)

804.2.1.2.1 Interrogation for air traffic services shall be performed on the modes described in 804.3.1.1.4.3 or 804.3.1.2. The uses of each mode shall be as follows:

- 1) Mode A — to elicit transponder replies for identity and surveillance.
- 2) Mode C — to elicit transponder replies for automatic pressure-altitude transmission and surveillance.
- 3) Intermode —
  - a) Mode A/C/S all-call: to elicit replies for surveillance of Mode A/C transponders and for the acquisition of Mode S transponders.
  - b) Mode A/C-only all-call: to elicit replies for surveillance of Mode A/C transponders. Mode S transponders do not reply.

4) Mode S —

- a) Mode S-only all-call: to elicit replies for acquisition of Mode S transponders.
- b) Broadcast: to transmit information to all Mode S transponders. No replies are elicited.
- c) Selective: for surveillance of, and communication with, individual Mode S transponders. For each interrogation, a reply is elicited only from the transponder uniquely addressed by the interrogation.

804.2.1.2.1.1 Administrations should co-ordinate with appropriate national and international authorities those implementation aspects of the SSR system which will permit its optimum use.

804.2.1.2.1.2 The assignment of interrogator identifier (II) codes, where necessary in areas of overlapping coverage, across international boundaries of flight information regions, shall be the subject of regional air navigation agreements.

804.2.1.2.1.3 The assignment of surveillance identifier (SI) codes, where necessary in areas of overlapping coverage, shall be the subject of regional air navigation agreements.

804.2.1.2.2 Mode A and Mode C interrogations shall be provided.

804.2.1.2.3 In areas where improved aircraft identification is necessary to enhance the effectiveness of the ATC system, SSR ground facilities having Mode S features should include aircraft identification capability.

804.2.1.2.4 SIDE-LOBE SUPPRESSION CONTROL INTERROGATION

804.2.1.2.4.1 Side-lobe suppression shall be provided in accordance with the provisions of 804.3.1.1.4 and 804.3.1.1.5 on all Mode A, Mode C and intermode interrogations.

804.2.1.2.4.2 Side-lobe suppression shall be provided in accordance with the provisions of 804.3.1.2.1.5.2.1 on all Mode S-only all-call interrogations.

**804.2.1.3 Transponder reply modes (air-to-ground)**

804.2.1.3.1 Transponders shall respond to Mode A interrogations in accordance with the provisions of 804.3.1.1.7.12.1 and to Mode C interrogations in accordance with the provisions of 804.3.1.1.7.12.2.

804.2.1.3.1.1 The pressure altitude reports contained in Mode S replies shall be derived as specified in 804.3.1.1.7.12.2.

804.2.1.3.2 Where the need for Mode C automatic pressure-altitude transmission capability within a specified airspace has been determined, transponders, when used within the airspace concerned, shall respond to Mode C interrogations with pressure-altitude encoding in the information pulses.

804.2.1.3.2.1 From 1 January 1999, all transponders, regardless of the airspace in which they will be used, shall respond to Mode C interrogations with pressure-altitude information.

804.2.1.3.2.2 The pressure-altitude information provided by Mode S transponders in response to selective interrogations (i.e. in the AC field) should be reported with the best altitude quantization increment available in the aircraft in accordance with the provisions of 804.3.1.2.6.5.4.

804.2.1.3.2.3 All Mode A/C transponders installed on or after 1 January 1992 shall report pressure-altitude encoded in the information pulses in Mode C replies.

804.2.1.3.2.4 All Mode S transponders installed on or after 1 January 1992 shall report pressure-altitude encoded in the information pulses in Mode C replies and in the AC field of Mode S replies.

804.2.1.3.2.5 All mode S transponder equipped aircraft with 7.62m (25 ft) or better pressure altitude sources shall report pressure altitude encoded in 7.62 m (25 ft) increments in the AC field of mode S replies from 1 January 2005.

804.2.1.3.2.6 When mode S transponder report altitude in 7.62 m (25 ft) increments, the reported value of the altitude shall be the value obtained by expressing the measured value of the uncorrected pressure altitude of the aircraft in 7.62 m (25 ft) increments.

804.2.1.3.3 Transponders used within airspace where the need for Mode S airborne capability has been determined shall also respond to intermode and Mode S interrogations in accordance with the applicable provisions of 804.3.1.2.

804.2.1.3.3.1 Requirements for mandatory carriage of SSR Mode S transponders shall be on the basis of regional air navigation agreements which shall specify the airspace and the airborne implementation timescales.

804.2.1.3.3.2 The agreements indicated in 804.2.1.3.3.1 shall provide at least seven years' notice.

#### **804.2.1.4 Mode A reply codes (information pulses)**

804.2.1.4.1 All transponders shall be capable of generating 4 096 reply codes conforming to the characteristics given in 804.3.1.1.6.2.

804.2.1.4.1.1 ATS authorities should establish the procedures for the allotment of SSR codes in conformity with Regional Air Navigation agreements, taking into account other users of the system.

804.2.1.4.2 The following Mode A codes shall be reserved for special purposes:

804.2.1.4.2.1 Code 7700 to provide recognition of an aircraft in an emergency.

804.2.1.4.2.2 Code 7600 to provide recognition of an aircraft with radio communication failure.

804.2.1.4.2.3 Code 7500 to provide recognition of an aircraft which is being subjected to unlawful interference.

804.2.1.4.3 Appropriate provisions shall be made in ground decoding equipment to ensure immediate recognition of Mode A codes 7500, 7600 and 7700.

804.2.1.4.4 Mode A code 0000 should be reserved for allocation subject to regional agreement, as a general purpose code.

804.2.1.4.5 Mode A code 2000 shall be reserved to provide recognition of an aircraft which has not received any instructions from air traffic control units to operate the transponder.

#### **804.2.1.5 Mode S airborne equipment capability**

804.2.1.5.1 All Mode S transponders shall conform to one of the following five levels:

- 804.2.1.5.1.1 Level 1 — Level 1 transponders shall have the capabilities prescribed for:
- a) Mode A identity and Mode C pressure-altitude reporting (804.3.1.1);
  - b) Intermodulation and Mode S all-call transactions (804.3.1.2.5);
  - c) Addressed surveillance altitude and identity transaction (804.3.1.2.6.1, 804.3.1.2.6.3, 804.3.1.2.6.5 and 804.3.1.2.6.7);
  - d) Lockout protocols (804.3.1.2.6.9);
  - e) Basic data protocols except data link capability reporting (804.3.1.2.6.10); and
  - f) air-air service and squitter transactions (804.3.1.2.8).
- 804.2.1.5.1.2 Level 2 — Level 2 transponders shall have the capabilities of 804.2.1.5.1.1 and also those prescribed for:
- a) Standard length communications (Comm-A and Comm-B) (804.3.1.2.6.2, 804.3.1.2.6.4, 804.3.1.2.6.6, 804.3.1.2.6.8 and 804.3.1.2.6.11);
  - b) data link capability reporting (804.3.1.2.6.10.2.2); and
  - c) Aircraft identification reporting (804.3.1.2.9).
- 804.2.1.5.1.3 Level 3 — Level 3 transponders shall have the capabilities of 804.2.1.5.1.2 and also those prescribed for ground-to-air extended length message (ELM) communications (804.3.1.2.7.1 to 804.3.1.2.7.5).
- 804.2.1.5.1.4 Level 4 — Level 4 transponders shall have the capabilities of 804.2.1.5.1.3 and also those prescribed for air-to-ground extended length message (ELM) communications (804.3.1.2.7.7 and 804.3.1.2.7.8).
- 804.2.1.5.1.5 Level 5 — Level 5 transponders shall have the capabilities of 804.2.1.5.1.4 and also those prescribed for enhanced Comm-B and extended length message (ELM) communications (804.3.1.2.6.11.3.4, 804.3.1.2.7.6 and 804.3.1.2.7.9).
- 804.2.1.5.1.6 Extended squitter — Extended squitter transponders shall have the capabilities of 804.2.1.5.1.2, 804.2.1.5.1.3, 804.2.1.5.1.4 or 804.2.1.5.1.5 and also those prescribed for extended squitter operation (804.3.1.2.8.6). Transponders with this capability shall be designated with a suffix “e”.
- 804.2.1.5.1.7 SI capability — Transponders with the ability to process SI codes shall have the capabilities of 804.2.1.5.1.2, 804.2.1.5.1.3, 804.2.1.5.1.4 or 804.2.1.5.1.5 and also those prescribed for SI code operation (804.3.1.2.3.2.1.4, 804.3.1.2.5.2.1, 804.3.1.2.6.1.3, 804.3.1.2.6.1.4.1, 804.3.1.2.6.9.1.1 and 804.3.1.2.6.9.2). Transponders with this capability shall be designated with a suffix “s”.
- 804.2.1.5.1.7.1 SI code capability shall be provided in accordance with the provision of 804.2.1.5.1.7 for all mode S transponders installed on or after 1<sup>st</sup> January 2003 and all mode S transponders by 1<sup>st</sup> January 2005.
- 804.2.1.5.1.8 Extended Squitter non – transponder devices. Devices that are capable of broadcasting extended squitters that are not part of a mode S transponder shall conform all of 1090Mhz RF signals in space requirements specified for all mode S transponder.
- 804.2.1.5.2 All Mode S transponders used by international civil air traffic shall conform, at least, to the requirements of Level 2 prescribed in 2.1.5.1.2.
- 804.2.1.5.3 Mode S transponders installed on aircraft with gross mass in excess of 5 700 kg or a maximum cruising true airspeed capability in excess of 324 km/h (175 kt) shall operate with antenna diversity as prescribed in 804.3.1.2.10.4 if:

- a) The aircraft individual certificate of airworthiness is first issued on or after 1 January 1990; or
- b) Mode S transponder carriage is required on the basis of regional air navigation agreement in accordance with 804.2.1.3.3.1 and 804.2.1.3.3.2.

#### 804.2.1.5.4 CAPABILITY REPORTING IN MODE S SQUITTERS

804.2.1.5.4.1 Capability reporting in Mode S acquisition squitters (unsolicited downlink transmissions) shall be provided in accordance with the provisions of 804.3.1.2.8.5.1 for all Mode S transponders installed on or after 1 January 1995.

804.2.1.5.4.2 Transponders equipped for extended squitter operation should have a means to disable acquisition squitters when extended squitters are being emitted.

#### 804.2.1.5.5 EXTENDED LENGTH MESSAGE (ELM) TRANSMIT POWER

804.2.1.5.5.1 In order to facilitate the conversion of existing Mode S transponders to include full Mode S capability, transponders originally manufactured before 1 January 1999 shall be permitted to transmit a burst of 16 ELM segments at a minimum power level of 20 dBW.

#### **804.2.1.6 2.1.6 SSR Mode S address (aircraft address)**

804.2.1.6.1 The SSR Mode S address shall be one of 16 777 214 twenty-four-bit aircraft addresses allocated by ICAO to the State of Registry or common mark registering authority and assigned as prescribed in 804.3.1.2.4.1.2.3.1.1 and the Appendix to Chapter 9, Part I, Volume III, Annex 10.

#### **804.2.2 HUMAN FACTORS CONSIDERATIONS**

804.2.2.1 Human Factors principles should be observed in the design and certification of surveillance radar and collision avoidance systems.

**804.3 SURVEILLANCE RADAR SYSTEMS**

**804.3.1 SECONDARY SURVEILLANCE RADAR (SSR) SYSTEM CHARACTERISTICS**

**804.3.1.1 Systems having only Mode A and Mode C capabilities**

804.3.1.1.1 INTERROGATION AND CONTROL (INTERROGATION SIDE-LOBE SUPPRESSION) RADIO FREQUENCIES (GROUND-TO-AIR)

804.3.1.1.1.1 The carrier frequency of the interrogation and control transmissions shall be 1 030 MHz.

804.3.1.1.1.2 The frequency tolerance shall be plus or minus 0.2 MHz.

804.3.1.1.1.3 The carrier frequencies of the control transmission and of each of the interrogation pulse transmissions shall not differ from each other by more than 0.2 MHz.

804.3.1.1.2 REPLY CARRIER FREQUENCY (AIR-TO-GROUND)

804.3.1.1.2.1 The carrier frequency of the reply transmission shall be 1 090 MHz.

804.3.1.1.2.2 The frequency tolerance shall be plus or minus 3 MHz.

804.3.1.1.3 POLARIZATION

804.3.1.1.3.1 Polarization of the interrogation, control and reply transmissions shall be predominantly vertical.

804.3.1.1.4 INTERROGATION MODES (SIGNALS-IN-SPACE)

804.3.1.1.4.1 The interrogation shall consist of two transmitted pulses designated P1 and P3. A control pulse P2 shall be transmitted following the first interrogation pulse P1.

804.3.1.1.4.2 Interrogation Modes A and C shall be as defined in 804.3.1.1.4.3.

804.3.1.1.4.3 The interval between P1 and P3 shall determine the mode of interrogation and shall be as follows:  
Mode A  $8 \pm 0.2$  microseconds  
Mode C  $21 \pm 0.2$  microseconds

804.3.1.1.4.4 The interval between P1 and P2 shall be 2.0 plus or minus 0.15 microseconds.

804.3.1.1.4.5 The duration of pulses P1, P2 and P3 shall be 0.8 plus or minus 0.1 microsecond.

804.3.1.1.4.6 The rise time of pulses P1, P2 and P3 shall be between 0.05 and 0.1 microsecond.

804.3.1.1.4.7 The decay time of pulses P1, P2 and P3 shall be between 0.05 and 0.2 microsecond.

804.3.1.1.5 INTERROGATOR AND CONTROL TRANSMISSION CHARACTERISTICS (INTERROGATION SIDE-LOBE SUPPRESSION — SIGNALS-IN-SPACE)

804.3.1.1.5.1 The radiated amplitude of P2 at the antenna of the transponder shall be:  
a) equal to or greater than the radiated amplitude of P1 from the side-lobe transmissions of the antenna radiating P1; and  
b) at a level lower than 9 dB below the radiated amplitude of P1, within the desired arc of interrogation.



804.3.1.1.5.2 Within the desired beamwidth of the directional interrogation (main lobe), the radiated amplitude of P3 shall be within 1 dB of the radiated amplitude of P1.

804.3.1.1.6 REPLY TRANSMISSION CHARACTERISTICS (SIGNALS-IN-SPACE)

804.3.1.1.6.1 Framing pulses. The reply function shall employ a signal comprising two framing pulses spaced 20.3 microseconds as the most elementary code.

804.3.1.1.6.2 Information pulses. Information pulses shall be spaced in increments of 1.45 microseconds from the first framing pulse. The designation and position of these information pulses shall be as follows:

Pulses	Position (microseconds)
C1	1.45
A1	2.90
C2	4.35
A2	5.80
C4	7.25
A4	8.70
X	10.15
B1	11.60
D1	13.05
B2	14.50
D2	15.95
B4	17.40
D4	18.85

804.3.1.1.6.3 Special position identification pulse (SPI). In addition to the information pulses provided, a special position identification pulse shall be transmitted but only as a result of manual (pilot) selection. When transmitted, it shall be spaced at an interval of 4.35 microseconds following the last framing pulse of Mode A replies only.

804.3.1.1.6.4 Reply pulse shape. All reply pulses shall have a pulse duration of 0.45 plus or minus 0.1microsecond, a pulse rise time between 0.05 and 0.1 microsecond and a pulse decay time between 0.05 and 0.2 microsecond. The pulse amplitude variation of one pulse with respect to any other pulse in a reply train shall not exceed 1 dB.

804.3.1.1.6.5 Reply pulse position tolerances. The pulse spacing tolerance for each pulse (including the last framing pulse) with respect to the first framing pulse of the reply group shall be plus or minus 0.10 microsecond. The pulse interval tolerance of the special position identification pulse with respect to the last framing pulse of the reply group shall be plus or minus 0.10 microsecond. The pulse spacing tolerance of any pulse in the reply group with respect to any other pulse (except the first framing pulse) shall not exceed plus or minus 0.15 microsecond.

804.3.1.1.6.6 Code nomenclature. The code designation shall consist of digits between 0 and 7 inclusive, and shall consist of the sum of the subscripts of the pulse numbers given in 804.3.1.1.6.2 above, employed as follows:

- Digit Pulse Group
- First (most significant) A
- Second B
- Third C
- Fourth D

804.3.1.1.7 TECHNICAL CHARACTERISTICS OF TRANSPONDERS WITH MODE A AND MODE C CAPABILITIES ONLY

804.3.1.1.7.1 Reply. The transponder shall reply (not less than 90 per cent triggering) when all of the following conditions have been met:

- a) the received amplitude of P3 is in excess of a level 1 dB below the received amplitude of P1 but no greater than 3 dB above the received amplitude of P1;
- b) either no pulse is received in the interval 1.3 microseconds to 2.7 microseconds after P1, or P1 exceeds by more than 9 dB any pulse received in this interval;
- c) the received amplitude of a proper interrogation is more than 10 dB above the received amplitude of random pulses where the latter are not recognized by the transponder as P1, P2 or P3.

804.3.1.1.7.2 The transponder shall not reply under the following conditions:

- a) to interrogations when the interval between pulses P1 and P3 differs from those specified in 804.3.1.1.4.3 by more than plus or minus 1.0 microsecond;

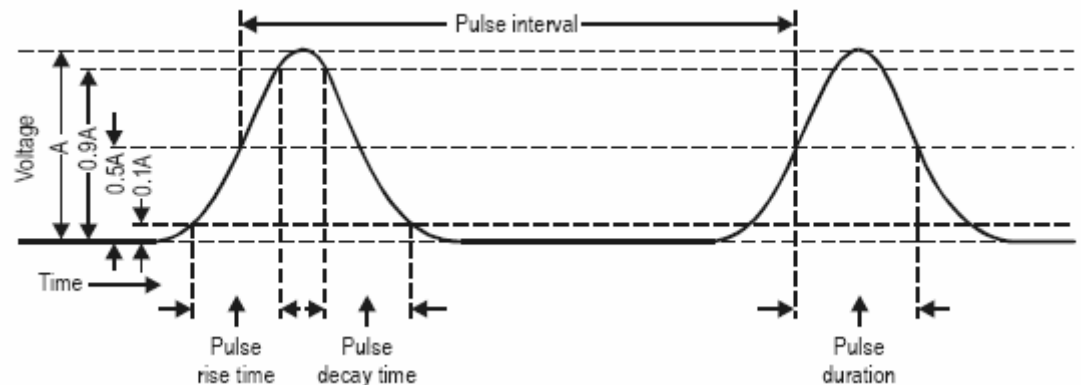

Definitions

- Phase reversal. A 180-degree change in the phase of the radio frequency carrier.
- Phase reversal duration. The time between the 10-degree and 170-degree points of a phase reversal.
- Pulse amplitude A. The peak voltage amplitude of the pulse envelope.
- Pulse decay time. The time between 0.9A and 0.1A on the trailing edge of the pulse envelope.
- Pulse duration. The time interval between 0.5A points on leading and trailing edges of the pulse envelope.
- Pulse interval. The time interval between the 0.5A point on the leading edge of the first pulse and the 0.5A point on the leading edge of the second pulse.
- Pulse rise time. The time between 0.1A and 0.9A on the leading edge of the pulse envelope.
- Time intervals. The intervals are referenced to:
  - a) the 0.5A point on the leading edge of a pulse;
  - b) the 0.5A point on the trailing edge of a pulse; or
  - c) the 90-degree point of a phase reversal.
- Transponder sensitivity and power reference point. The antenna end of the transmission line of the transponder.

Note.— The 90-degree point of a phase reversal can be approximated by the minimum amplitude point on the envelope amplitude transient associated with the phase reversal and the phase reversal duration can be approximated by the time between the 0.8A points of the envelope amplitude transient.

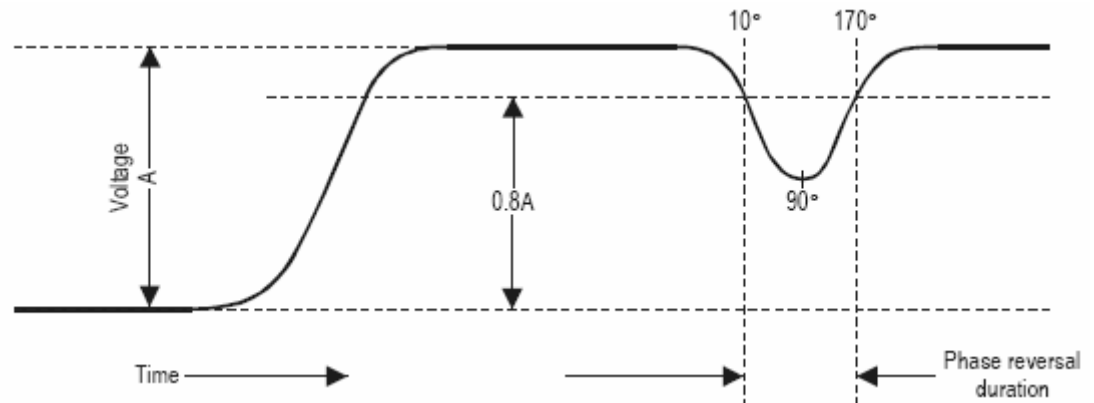

**Figure 3-1. Definitions of secondary surveillance radar waveform shapes, intervals and the reference point for sensitivity and power**

- b) Upon receipt of any single pulse which has no amplitude variations approximating a normal interrogation condition.

804.3.1.1.7.3 Dead time. After recognition of a proper interrogation, the transponder shall not reply to any other interrogation, at least for the duration of the reply pulse train. This dead time shall end no later than 125 microseconds after the transmission of the last reply pulse of the group.

#### 804.3.1.1.7.4 SUPPRESSION

804.3.1.1.7.4.1 The transponder shall be suppressed when the received amplitude of P2 is equal to, or in excess of, the received amplitude of P1 and spaced 2.0 plus or minus 0.15 microseconds. The detection of P3 is not required as a prerequisite for initiation of suppression action.

804.3.1.1.7.4.2 The transponder suppression shall be for a period of 35 plus or minus 10 microseconds.

804.3.1.1.7.4.2.1 The suppression shall be capable of being reinitiated for the full duration within 2 microseconds after the end of any suppression period.

#### 804.3.1.1.7.5 RECEIVER SENSITIVITY AND DYNAMIC RANGE

804.3.1.1.7.5.1 The minimum triggering level of the transponder shall be such that replies are generated to at least 90 per cent of the interrogation signals when:

- a) the two pulses P1 and P3 constituting an interrogation are of equal amplitude and P2 is not detected;  
and
- b) the amplitude of these signals is nominally 71 dB below 1 mW, with limits between 69 dB and 77 dB below 1 mW.

- 804.3.1.1.7.5.2 The reply and suppression characteristics shall apply over a received amplitude of P1 between minimum triggering level and 50 dB above that level.
- 804.3.1.1.7.5.3 The variation of the minimum triggering level between modes shall not exceed 1 dB for nominal pulse spacings and pulse widths.
- 804.3.1.1.7.6 Pulse duration discrimination. Signals of received amplitude between minimum triggering level and 6 dB above this level, and of a duration less than 0.3 microsecond, shall not cause the transponder to initiate reply or suppression action. With the exception of single pulses with amplitude variations approximating an interrogation, any single pulse of a duration more than 1.5 microseconds shall not cause the transponder to initiate reply or suppression action over the signal amplitude range of minimum triggering level (MTL) to 50 dB above that level.
- 804.3.1.1.7.7 Echo suppression and recovery. The transponder shall contain an echo suppression facility designed to permit normal operation in the presence of echoes of signals-in-space. The provision of this facility shall be compatible with the requirements for suppression of side lobes given in 804.3.1.1.7.4.1.
- 804.3.1.1.7.7.1 Desensitization. Upon receipt of any pulse more than 0.7 microsecond in duration, the receiver shall be desensitized by an amount that is within at least 9 dB of the amplitude of the desensitizing pulse but shall at no time exceed the amplitude of the desensitizing pulse, with the exception of possible overshoot during the first microsecond following the desensitizing pulse.
- 804.3.1.1.7.7.2 Recovery. Following desensitization, the receiver shall recover sensitivity (within 3 dB of minimum triggering level) within 15 microseconds after reception of a desensitizing pulse having a signal strength up to 50 dB above minimum triggering level. Recovery shall be at an average rate not exceeding 4.0 dB per microsecond.
- 804.3.1.1.7.8 Random triggering rate. In the absence of valid interrogation signals, Mode A/C transponders shall not generate more than 30 unwanted Mode A or Mode C replies per second as integrated over an interval equivalent to at least 300 random triggers, or 30 seconds, whichever is less. This random triggering rate shall not be exceeded when all possible interfering equipments installed in the same aircraft are operating at maximum interference levels.
- 804.3.1.1.7.9 REPLY RATE
- 804.3.1.1.7.9.1 The transponder shall be capable of at least 1 200 replies per second for a 15-pulse coded reply, except that, for transponder installations used solely below 4 500 m (15 000 ft), or below a lesser altitude established by the appropriate authority or by regional air navigation agreement, transponders capable of at least 1 000 replies per second for a 15-pulse coded reply shall be permitted.
- 804.3.1.1.7.9.2 Reply rate limit control. To protect the system from the effects of transponder over interrogation by preventing response to weaker signals when a predetermined reply rate has been reached, a sensitivity reduction type reply limit control shall be incorporated in the equipment. The range of this control shall permit adjustment, as a minimum, to any value between 500 and 2 000 replies per second, or to the maximum reply rate capability if less than 2 000 replies per second, without regard to the number of pulses in each reply. Sensitivity reduction in excess of 3 dB shall not take effect until 90 per cent of the selected value is exceeded. Sensitivity reduction shall be at least 30 dB for rates in excess of 150 per cent of the selected value.
- 804.3.1.1.7.9.3 The reply rate limit should be set at 1 200 replies per second, or the maximum value below 1 200 replies per second of which the transponder is capable.

804.3.1.1.7.10 Reply delay and jitter. The time delay between the arrival, at the transponder receiver, of the leading edge of P3 and the transmission of the leading edge of the first pulse of the reply shall be 3 plus or minus 0.5 microseconds. The total jitter of the reply pulse code group, with respect to P3, shall not exceed 0.1 microsecond for receiver input levels between 3 dB and 50 dB above minimum triggering level. Delay variations between modes on which the transponder is capable of replying shall not exceed 0.2 microsecond.

#### 804.3.1.1.7.11 TRANSPONDER POWER OUTPUT AND DUTY CYCLE

804.3.1.1.7.11.1 The peak pulse power available at the antenna end of the transmission line of the transponder shall be at least 21 dB and not more than 27 dB above 1 W, except that for transponder installations used solely below 4 500 m (15 000 ft), or below a lesser altitude established by the appropriate authority or by regional air navigation agreement, a peak pulse power available at the antenna end of the transmission line of the transponder of at least 18.5 dB and not more than 27 dB above 1 W shall be permitted.

804.3.1.1.7.11.2 The peak pulse power specified in 3.1.1.7.11.1 above should be maintained over a range of replies from code 0000 at a rate of 400 replies per second to a maximum pulse content at a rate of 1 200 replies per second or a maximum value below 1 200 replies per second of which the transponder is capable.

#### 804.3.1.1.7.12 REPLY CODES

804.3.1.1.7.12.1 Identification. The reply to a Mode A interrogation shall consist of the two framing pulses specified in 804.3.1.1.6.1 together with the information pulses (Mode A code) specified in 804.3.1.1.6.2.

804.3.1.1.7.12.1.1 The Mode A code shall be manually selected from the 4 096 codes available.

804.3.1.1.7.12.2 Pressure-altitude transmission. The reply to Mode C interrogation shall consist of the two framing pulses specified in 804.3.1.1.6.1 above. When digitized pressure-altitude information is available, the information pulses specified in 3.1.1.6.2 shall also be transmitted.

804.3.1.1.7.12.2.1 Transponders shall be provided with means to remove the information pulses but to retain the framing pulses when the provision of 804.3.1.1.7.12.2.4 below is not complied with in reply to Mode C interrogation.

804.3.1.1.7.12.2.2 The information pulses shall be automatically selected by an analog-to-digital converter connected to a pressure-altitude data source in the aircraft referenced to the standard pressure setting of 1 013.25 hectopascals.

804.3.1.1.7.12.2.3 Pressure-altitude shall be reported in 100-ft increments by selection of pulses as shown in Appendix 1 to this chapter.

804.3.1.1.7.12.2.4 The digitizer code selected shall correspond to within plus or minus 38.1 m (125 ft), on a 95 per cent probability basis, with the pressure-altitude information (referenced to the standard pressure setting of 1 013.25 hectopascals), used on board the aircraft to adhere to the assigned flight profile.

804.3.1.1.7.13 Transmission of the special position identification (SPI) pulse. When required, this pulse shall be transmitted with Mode A replies, as specified in 3.1.1.6.3, for a period of between 15 and 30 seconds.

804.3.1.1.7.14.1 The transponder antenna system, when installed on an aircraft, shall have a radiation pattern which is essentially omnidirectional in the horizontal plane.

804.3.1.1.7.14.2 The vertical radiation pattern should be nominally equivalent to that of a quarter-wave monopole on a ground plane.

#### 804.3.1.1.8 TECHNICAL CHARACTERISTICS OF GROUND INTERROGATORS WITH MODE A AND MODE C CAPABILITIES ONLY

804.3.1.1.8.1 Interrogation repetition frequency. The maximum interrogation repetition frequency shall be 450 interrogations per second.

804.3.1.1.8.1.1 To minimize unnecessary transponder triggering and the resulting high density of mutual interference, all interrogators should use the lowest practicable interrogator repetition frequency that is consistent with the display characteristics, interrogator antenna beam width and antenna rotation speed employed.

#### 804.3.1.1.8.2 RADIATED POWER

In order to minimize system interference the effective radiated power of interrogators should be reduced to the lowest value consistent with the operationally required range of each individual interrogator site.

804.3.1.1.8.3 When Mode C information is to be used from aircraft flying below transition levels, the altimeter pressure reference datum should be taken into account.

#### 804.3.1.1.9 INTERROGATOR RADIATED FIELD PATTERN

The beam width of the directional interrogator antenna radiating P3 should not be wider than it is operationally required. The side- and back-lobe radiation of the directional antenna should be at least 24 dB below the peak of the main-lobe radiation.

#### 804.3.1.1.10 INTERROGATOR MONITOR

804.3.1.1.10.1 The range and azimuth accuracy of the ground interrogator shall be monitored at sufficiently frequent intervals to ensure system integrity.

804.3.1.1.10.2 In addition to range and azimuth monitoring, provision should be made to monitor continuously the other critical parameters of the ground interrogator for any degradation of performance exceeding the allowable system tolerances and to provide an indication of any such occurrence.

#### 804.3.1.1.11 SPURIOUS EMISSIONS AND SPURIOUS RESPONSES

##### 804.3.1.1.11.1 SPURIOUS RADIATION

CW radiation should not exceed 76 dB below 1 W for the interrogator and 70 dB below 1 W for the transponder.

##### 804.3.1.1.11.2 SPURIOUS RESPONSES

The response of both airborne and ground equipment to signals not within the receiver pass band should be at least 60 dB below normal sensitivity.

#### **804.3.1.2 Systems having Mode S capabilities**

- 804.3.1.2.1 Interrogation signals-in-space characteristics. The paragraphs herein describe the signals-in-space as they can be expected to appear at the antenna of the transponder.
- 804.3.1.2.1.1 Interrogation carrier frequency. The carrier frequency of all interrogations (uplink transmissions) from ground facilities with Mode S capabilities shall be 1 030 plus or minus 0.01 MHz.
- 804.3.1.2.1.2 Interrogation spectrum. The spectrum of a Mode S interrogation about the carrier frequency shall not exceed the limits specified in Figure 3-2.
- 804.3.1.2.1.3 Polarization. Polarization of the interrogation and control transmissions shall be nominally vertical.
- 804.3.1.2.1.4 Modulation. For Mode S interrogations, the carrier frequency shall be pulse modulated. In addition, the data pulse, P6, shall have internal phase modulation.
- 804.3.1.2.1.4.1 Pulse modulation. Intermode and Mode S interrogations shall consist of a sequence of pulses. The pulses which may be used to form a specific interrogation are designated P1, P2, P3, P4, P5 and P6. Pulse shapes shall be as defined in Table 3-1. All values are in microseconds.
- 804.3.1.2.1.4.2 Phase modulation. The short (16.25-microsecond) and long (30.25-microsecond) P6 pulses of 804.3.1.2.1.4.1 shall have internal binary differential phase modulation consisting of 180-degree phase reversals of the carrier at a 4 megabit per second rate.
- 804.3.1.2.1.4.2.1 Phase reversal duration. The duration of the phase reversal shall be less than 0.08 microsecond and the phase shall advance (or retard) monotonically throughout the transition region. There shall be no amplitude modulation applied during the phase transition.
- 804.3.1.2.1.4.2.2 Phase relationship. The tolerance on the 0 and 180-degree phase relationship between successive chips and on the sync phase reversal (804.3.1.2.1.5.2.2) within the P6 pulse shall be plus or minus 5 degrees.
- 804.3.1.2.1.5 Pulse and phase reversal sequences. Specific sequences of the pulses or phase reversals described in 804.3.1.2.1.4 shall constitute interrogations.

**Table 3-1. Pulse shapes — Mode S and intermode interrogations**

<i>Pulse</i>	<i>Duration</i>	<i>Duration tolerance</i>	<i>(Rise time)</i>		<i>(Decay time)</i>	
			<i>Min.</i>	<i>Max.</i>	<i>Min.</i>	<i>Max.</i>
$P_1, P_2, P_3, P_5$	0.8	±0.1	0.05	0.1	0.05	0.2
$P_4$ (short)	0.8	±0.1	0.05	0.1	0.05	0.2
$P_4$ (long)	1.6	±0.1	0.05	0.1	0.05	0.2
$P_6$ (short)	16.25	±0.25	0.05	0.1	0.05	0.2
$P_6$ (long)	30.25	±0.25	0.05	0.1	0.05	0.2

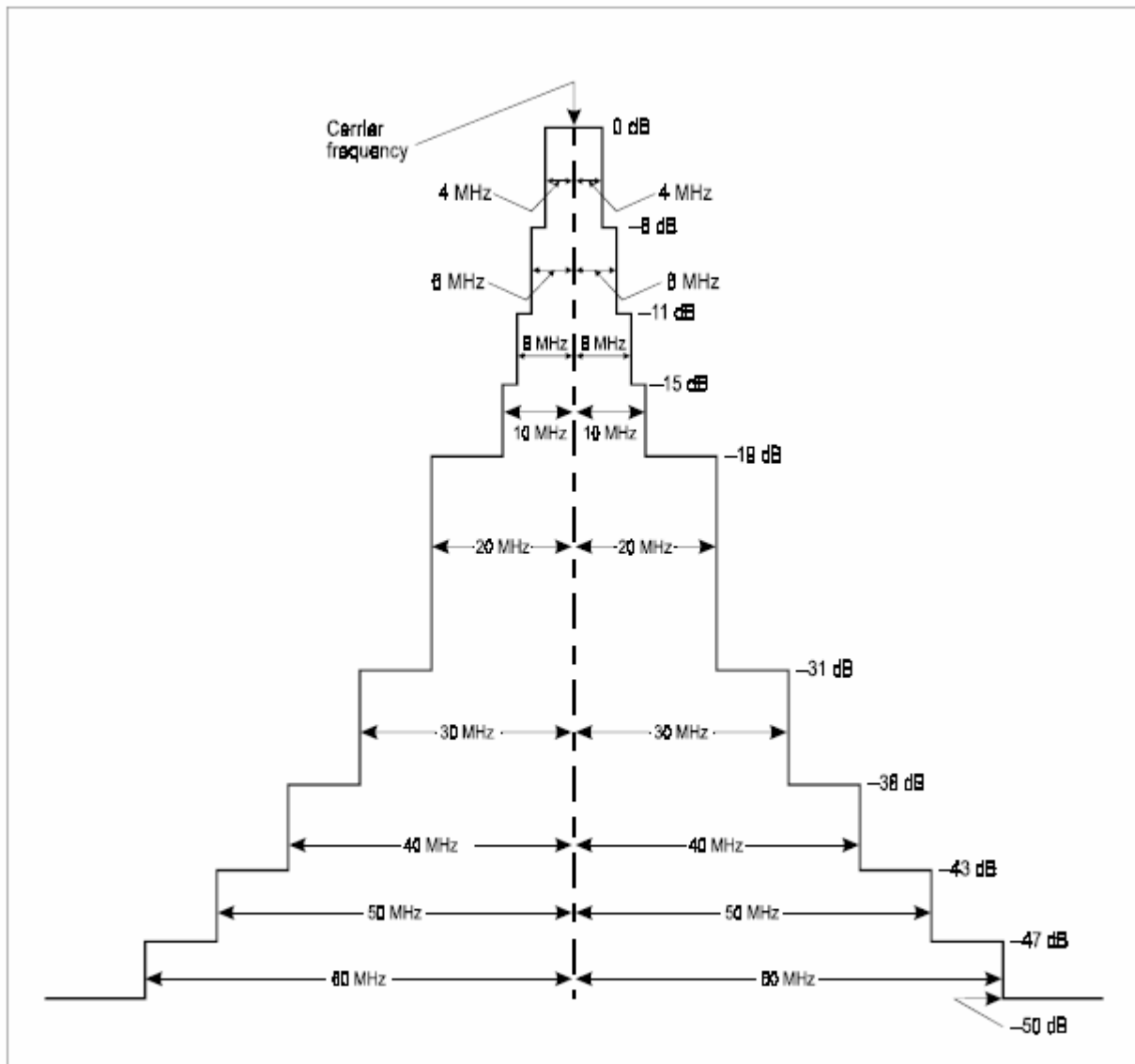

**Figure 3.2 Required spectrum limits for interrogator transmitter**

804.3.1.2.1.5.1 Intermode interrogation

804.3.1.2.1.5.1.1 Mode A/C/S all-call interrogation. This interrogation shall consist of three pulses: P1, P3, and the long P4 as shown in Figure 3-3. One or two control pulses (P2 alone, or P1 and P2) shall be transmitted using a separate antenna pattern to suppress responses from aircraft in the side lobes of the interrogator antenna.

804.3.1.2.1.5.1.2 Mode A/C-only all-call interrogation. This interrogation shall be identical to that of the Mode A/C/S all-call interrogation except that the short P4 pulse shall be used.

804.3.1.2.1.5.1.3 Pulse intervals. The pulse intervals between P1, P2 and P3 shall be as defined in 804.3.1.1.4.3 and 804.3.1.1.4.4. The pulse interval between P3 and P4 shall be 2 plus or minus 0.05 microsecond.



804.3.1.2.1.5.1.4 Pulse amplitudes. Relative amplitudes between pulses P1, P2 and P3 shall be in accordance with 804.3.1.1.5. The amplitude of P4 shall be within 1 dB of the amplitude of P3.

804.3.1.2.1.5.2 Mode S interrogation. The Mode S interrogation shall consist of three pulses: P1, P2 and P6 as shown in Figure 3-4.

804.3.1.2.1.5.2.1 Mode S side-lobe suppression. The P5 pulse shall be used with the Mode S-only all-call interrogation (UF = 11, see 3.1.2.5.2) to prevent replies from aircraft in the side and back lobes of the antenna (804.3.1.2.1.5.2.5). When used, P5 shall be transmitted using a separate antenna pattern.

804.3.1.2.1.5.2.2 Sync phase reversal. The first phase reversal in the P6 pulse shall be the sync phase reversal. It shall be the timing reference for subsequent transponder operations related to the interrogation.

804.3.1.2.1.5.2.3 Data phase reversals. Each data phase reversal shall occur only at a time interval (N times 0.25) plus or minus 0.02 microsecond (N equal to, or greater than 2) after the sync phase reversal. The 16.25-microsecond P6 pulse shall contain at most 56 data phase reversals. The 30.25-microsecond P6 pulse shall contain at most 112 data phase reversals. The last chip, that is the 0.25-microsecond time interval following the last data phase reversal position, shall be followed by a 0.5-microsecond guard interval.

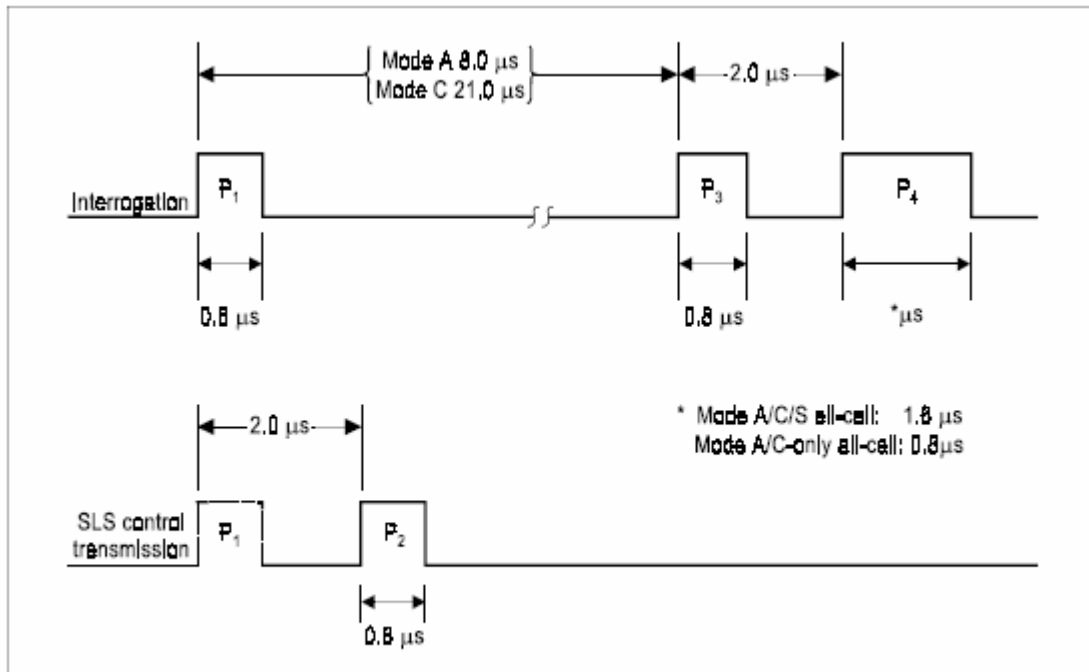
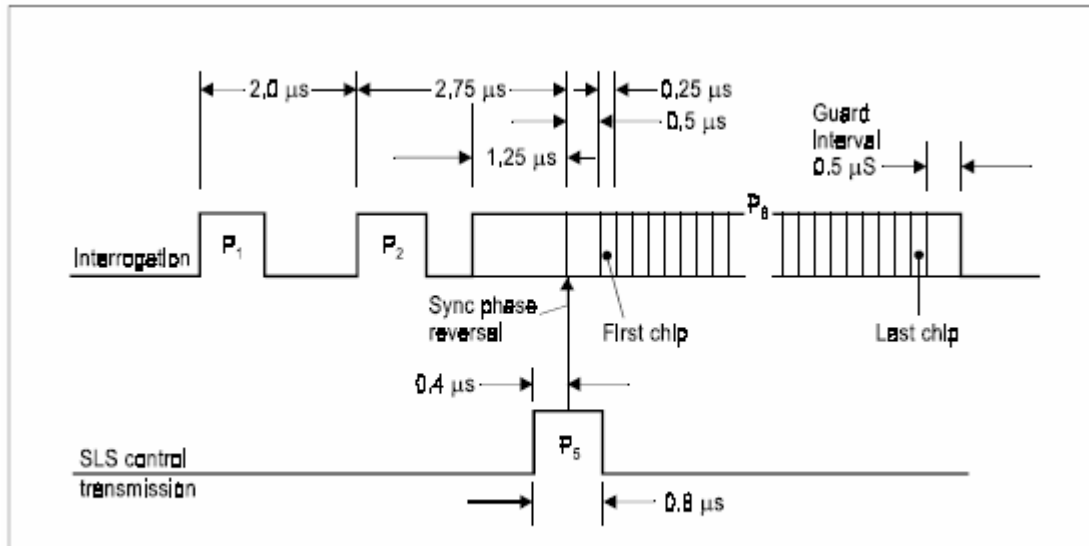

Figure 3-3 Intermode interrogation pulse sequence



**Figure 3-4 Mode S interrogation pulse sequence**

804.3.1.2.1.5.2.4 Intervals. The pulse interval between P1 and P2 shall be 2 plus or minus 0.05 microsecond. The interval between the leading edge of P2 and the sync phase reversal of P6 shall be 2.75 plus or minus 0.05 microsecond. The leading edge of P6 shall occur 1.25 plus or minus 0.05 microsecond before the sync phase reversal. P5, if transmitted, shall be centred over the sync phase reversal; the leading edge of P5 shall occur 0.4 plus or minus 0.05 microsecond before the sync phase reversal.

804.3.1.2.1.5.2.5 Pulse amplitudes. The amplitude of P2 and the amplitude of the first microsecond of P6 shall be greater than the amplitude of P1 minus 0.25 dB. Exclusive of the amplitude transients associated with phase reversals, the amplitude variation of P6 shall be less than 1 dB and the amplitude variation between successive chips in P6 shall be less than 0.25 dB. The radiated amplitude of P5 at the antenna of the transponder shall be:

- a) equal to or greater than the radiated amplitude of P6 from the side-lobe transmissions of the antenna radiating P6; and
- b) at a level lower than 9 dB below the radiated amplitude of P6 within the desired arc of interrogation.

804.3.1.2.2 REPLY SIGNALS-IN-SPACE CHARACTERISTICS

804.3.1.2.2.1 Reply carrier frequency. The carrier frequency of all replies (downlink transmissions) from transponders with Mode S capabilities shall be 1 090 plus or minus 1 MHz.

804.3.1.2.2.2 Reply spectrum. The spectrum of a Mode S reply about the carrier frequency shall not exceed the limits specified in Figure 3-5.

804.3.1.2.2.3 Polarization. Polarization of the reply transmissions shall be nominally vertical.

804.3.1.2.2.4 Modulation. The Mode S reply shall consist of a preamble and a data block. The preamble shall be a 4-pulse sequence and the data block shall be binary pulse-position modulated at a 1 megabit per second data rate.

- 804.3.1.2.2.4.1 Pulse shapes. Pulse shapes shall be as defined in Table 3-2. All values are in microseconds.
- 804.3.1.2.2.5 Mode S reply. The Mode S reply shall be as shown in Figure 3-6. The data block in Mode S replies shall consist of either 56 or 112 information bits.
- 804.3.1.2.2.5.1 Pulse intervals. All reply pulses shall start at a defined multiple of 0.5 microsecond from the first transmitted pulse. The tolerance in all cases shall be plus or minus 0.05 microsecond.
- 804.3.1.2.2.5.1.1 Reply preamble. The preamble shall consist of four pulses, each with a duration of 0.5 microsecond. The pulse intervals from the first transmitted pulse to the second, third and fourth transmitted pulses shall be 1, 3.5 and 4.5 microseconds respectively.
- 804.3.1.2.2.5.1.2 Reply data pulses. The reply data block shall begin 8 microseconds after the leading edge of the first transmitted pulse. Either 56 or 112 one-microsecond bit intervals shall be assigned to each transmission. A 0.5-microsecond pulse shall be transmitted either in the first or in the second half of each interval. When a pulse transmitted in the second half of one interval is followed by another pulse transmitted in the first half of the next interval, the two pulses merge and a one-microsecond pulse shall be transmitted.
- 804.3.1.2.2.5.2 Pulse amplitudes. The pulse amplitude variation between one pulse and any other pulse in a Mode S reply shall not exceed 2 dB.
- 804.3.1.2.3 MODE S DATA STRUCTURE
- 804.3.1.2.3.1 DATA ENCODING
- 804.3.1.2.3.1.1 Interrogation data. The interrogation data block shall consist of the sequence of 56 or 112 data chips positioned after the data phase reversals within P6 (804.3.1.2.1.5.2.3). A 180-degree carrier phase reversal preceding a chip shall characterize that chip as a binary ONE. The absence of a preceding phase reversal shall denote a binary ZERO.
- 804.3.1.2.3.1.2 Reply data. The reply data block shall consist of 56 or 112 data bits formed by binary pulse position modulation encoding of the reply data as described in 804.3.1.2.2.5.1.2. A pulse transmitted in the first half of the interval shall represent a binary ONE whereas a pulse transmitted in the second half shall represent a binary ZERO.
- 804.3.1.2.3.1.3 Bit numbering. The bits shall be numbered in the order of their transmission, beginning with bit 1. Unless otherwise stated, numerical values encoded by groups (fields) of bits shall be encoded using positive binary notation and the first bit transmitted shall be the most significant bit (MSB). Information shall be coded in fields which consist of at least one bit.

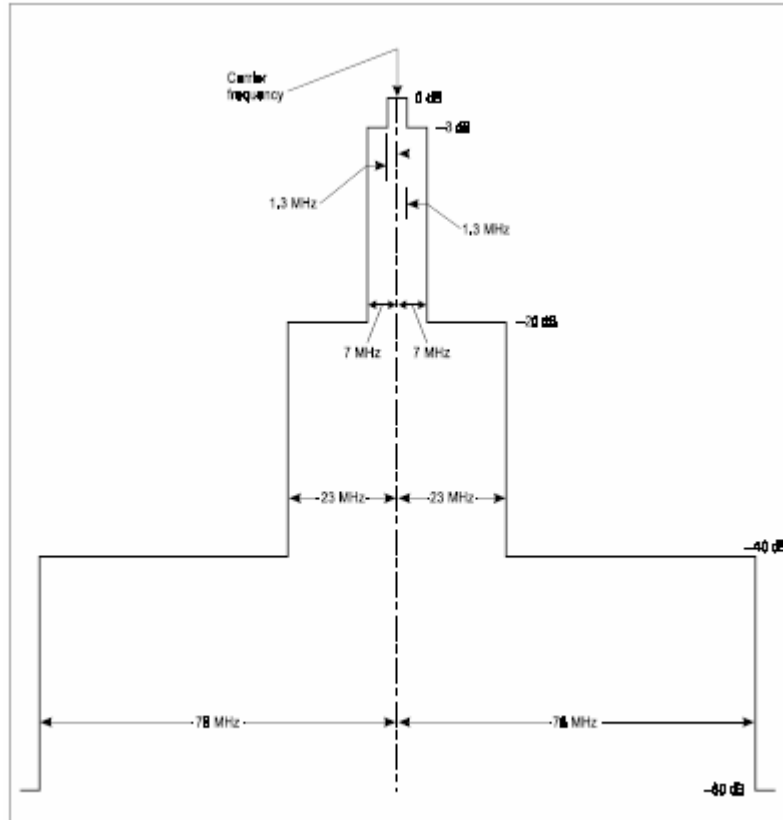

Figure 3-5 Required spectrum limits for transponder transmitter

Table 3-2. Pulse shapes — Mode S replies

Pulse duration	Duration tolerance	(Rise time)		(Decay time)	
		Min.	Max.	Min.	Max.
0.5	±0.05	0.05	0.1	0.05	0.2
1.0	±0.05	0.05	0.1	0.05	0.2

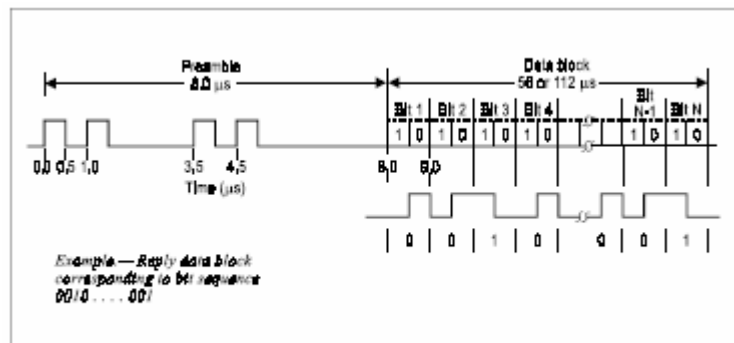

Figure 3-6 Mode S reply

Format No.	UF								
0	00000	3	RL:1	4	AQ:1	18	AP:24	.... Short air-air surveillance (ACAS)	
1	00001			27 or 63			AP:24		
2	00010			27 or 63			AP:24		
3	00011			27 or 63			AP:24		
4	00100	PC:3	RR:5	DI:3	SD:16		AP:24	.... Surveillance, altitude request	
5	00101	PC:3	RR:5	DI:3	SD:16		AP:24	.... Surveillance, identity request	
6	00110			27 or 63			AP:24		
7	00111			27 or 63			AP:24		
8	01000			27 or 63			AP:24		
9	01001			27 or 63			AP:24		
10	01010			27 or 63			AP:24		
11	01011	PR:4	IC:4	CL:3	16		AP:24	.... Mode S only all-call	
12	01100			27 or 63			AP:24		
13	01101			27 or 63			AP:24		
14	01110			27 or 63			AP:24		
15	01111			27 or 63			AP:24		
16	10000	3	RL:1	4	AQ:1	18	MU:56	AP:24	.... Long air-air surveillance (ACAS)
17	10001			27 or 63			AP:24		
18	10010			27 or 63			AP:24		
19	10011			27 or 63			AP:24		
20	10100	PC:3	RR:5	DI:3	SD:16	MA:56	AP:24	.... Comm-A, altitude request	
21	10101	PC:3	RR:5	DI:3	SD:16	MA:56	AP:24	.... Comm-A, identity request	
22	10110			27 or 63			AP:24		
23	10111			27 or 63			AP:24		
24	11	RC:2	NC:4	MC:80			AP:24	.... Comm-C (ELM)	

**Figure 3-7. Summary of Mode S interrogation or uplink formats**

NOTES:

1. XX:M denotes a field designated “XX” which is assigned M bits.
2. N denotes unassigned coding space with N available bits. These shall be coded as ZEROs for transmission.

3. For uplink formats (UF) 0 to 23 the format number corresponds to the binary code in the first five bits of the interrogation. Format number 24 is defined as the format beginning with “11” in the first two bit positions while the following three bits vary with the interrogation content.

4. All formats are shown for completeness, although a number of them are unused. Those formats for which no application is presently defined remain undefined in length. Depending on future assignment they may be short (56 bits) or long (112 bits) formats. Specific formats associated with Mode S capability levels are described in later paragraphs.
5. The PC, RR, DI and SD fields do not apply to a Comm-A broadcast interrogation.

Format No.	UF								
0	00000	VS:1	7	RI:4	2	AC:13	AP:24	.... Short air-air surveillance (ACAS)	
1	00001	27 or 83					P:24		
2	00010	27 or 83					P:24		
3	00011	27 or 83					P:24		
4	00100	FS:3	DR:5	UM:6	AC:13	AP:24	.... Surveillance, altitude reply		
5	00101	FS:3	DR:5	UM:6	ID:13	AP:24	.... Surveillance, identity reply		
6	00110	27 or 83					P:24		
7	00111	27 or 83					P:24		
8	01000	27 or 83					P:24		
9	01001	27 or 83					P:24		
10	01010	27 or 83					P:24		
11	01011	CA:3	AA:24	PI:24				.... All-call reply	
12	01100	27 or 83					P:24		
13	01101	27 or 83					P:24		
14	01110	27 or 83					P:24		
15	01111	27 or 83					P:24		
16	10000	VS:1	7	RI:4	2	AC:13	MV:56	AP:24	.... Long air-air surveillance (ACAS)
17	10001	CA:3	AA:24	ME:56	PI:24				.... Extended squitter
18	10010	27 or 83					P:24		
19	10011	27 or 83					P:24		
20	10100	FS:3	D:5	UM:6	AC:13	MB:56	AP:24	.... Comm-B, altitude reply	
21	10101	FS:3	DR:5	UM:6	ID:13	MB:56	AP:24	.... Comm-B, altitude reply	
22	10110	27 or 83					P:24		
23	10111	27 or 83					P:24		
24	11	1	KE:1	ND:4	MD:80	AP:24	.... Comm-D (ELM)		

**Figure 3-8. Summary of Mode S reply or downlink formats**

NOTES:

1 XX:M denotes a field designated “XX” which is assigned M bits. P:24 denotes a 24-bit field reserved for parity information.

2 N denotes unassigned coding space with N available bits. These shall be coded as ZEROs for transmission.

3 For downlink formats (DF) 0 to 23 the format number corresponds to the binary code in the first five bits of the reply. Format number 24 is defined as the format beginning with “11” in the first two bit positions while the following three bits vary with the reply content.

4 All formats are shown for completeness, although a number of them are unused. Those formats for which no application is presently defined remain undefined in length. Depending on future assignment they may be short (56 bits) or long (112 bits) formats. Specific formats associated with Mode S capability levels are described in later paragraphs.

#### 804.3.1.2.3.2 FORMATS OF MODE S INTERROGATIONS AND REPLIES

804.3.1.2.3.2.1 Essential fields. Every Mode S transmission shall contain two essential fields. One is a descriptor which shall uniquely define the format of the transmission. This shall appear at the beginning of the transmission for all formats. The descriptors are designated by the UF (uplink format) or DF (downlink format) fields. The second essential field shall be a 24-bit field appearing at the end of each transmission and shall contain parity information. In all uplink and in currently defined downlink formats parity information shall be overlaid either on the aircraft address (804.3.1.2.4.1.2.3.1) or on the interrogator identifier according to 804.3.1.2.3.3.2. The designators are AP (address/parity) or PI (parity/interrogator identifier).

804.3.1.2.3.2.1.1 UF: Uplink format. This uplink format field (5 bits long except in format 24 where it is 2 bits long) shall serve as the uplink format descriptor in all Mode S interrogations and shall be coded according to Figure 3-7.

804.3.1.2.3.2.1.2 DF: Downlink format. This downlink format field (5 bits long except in format 24 where it is 2 bits long) shall serve as the downlink format descriptor in all Mode S replies and shall be coded according to Figure 3-8.

804.3.1.2.3.2.1.3 AP: Address/parity. This 24-bit (33-56 or 89-112) field shall appear in all uplink and currently defined downlink formats except the Mode S-only all-call reply, DF = 11. The field shall contain parity overlaid on the aircraft address according to 804.3.1.2.3.3.2.

804.3.1.2.3.2.1.4 PI: Parity/interrogator identifier. This 24-bit (33-56) or (89-112) downlink field shall have parity overlaid on the interrogator's identity code according to 804.3.1.2.3.3.2 and shall appear in the Mode S all-call reply, DF = 11 and in the extended squitter, DF = 17. If the reply is made in response to a Mode A/C/S all-call, a Mode S-only all-call with CL field (804.3.1.2.5.2.1.3) and IC field (804.3.1.2.5.2.1.2) equal to 0, or is an acquisition or extended squitter (804.3.1.2.8.5, 804.3.1.2.8.6), the II and the SI codes shall be 0.

804.3.1.2.3.2.2 Unassigned coding space. Unassigned coding space shall contain all ZEROs as transmitted by interrogators and transponders.

804.3.1.2.3.2.3 Zero and unassigned codes. A zero code assignment in all defined fields shall indicate that no action is required by the field. In addition, codes not assigned within the fields shall indicate that no action is required.



**Table 3-3. Field definitions**

<i>Field</i>		<i>Format</i>		<i>Reference</i>
<i>Designator</i>	<i>Function</i>	<i>UF</i>	<i>DF</i>	
AA	Address announced		11	3.1.2.5.2.2.2
AC	Altitude code		4, 20	3.1.2.6.5.4
AP	Address/parity	All	0, 4, 5, 16, 20, 21, 24	3.1.2.3.2.1.3
AQ	Acquisition	0		3.1.2.8.1.1
CA	Capability		11	3.1.2.5.2.2.1
CC	Cross-link capability		0	3.1.2.8.2.3
CL	Code label	11		3.1.2.5.2.1.3
DF	Downlink format		All	3.1.2.3.2.1.2
DI	Designator identification	4, 5, 20, 21		3.1.2.6.1.3
DR	Downlink request		4, 5, 20, 21	3.1.2.6.5.2
DS	Data selector	0		3.1.2.8.1.3
FS	Flight status		4, 5, 20, 21	3.1.2.6.5.1
IC	Interrogator code	11		3.1.2.5.2.1.2
ID	Identity		5, 21	3.1.2.6.7.1
KE	Control, ELM		24	3.1.2.7.3.1
MA	Message, Comm-A	20, 21		3.1.2.6.2.1
MB	Message, Comm-B		20, 21	3.1.2.6.6.1
MC	Message, Comm-C	24		3.1.2.7.1.3
MD	Message, Comm-D		24	3.1.2.7.3.3
ME	Message, extended squitter		17	3.1.2.8.6.2
MU	Message, ACAS	16		4.3.8.4
MV	Message, ACAS		16	3.1.2.8.3.1, 4.3.8.4
NC	Number of C-segment	24		3.1.2.7.1.2
ND	Number of D-segment		24	3.1.2.7.3.2
PC	Protocol	4, 5, 20, 21		3.1.2.6.1.1
PI	Parity/interrogator identifier		11, 17	3.1.2.3.2.1.4
PR	Probability of reply	11		3.1.2.5.2.1.1
RC	Reply control	24		3.1.2.7.1.1
RI	Reply information		0	3.1.2.8.2.2
RLS	Reply length	0		3.1.2.8.1.2
RR	Reply request	4, 5, 20, 21		3.1.2.6.1.2
SD	Special designator	4, 5, 20, 21		3.1.2.6.1.4
UF	Uplink format	All		3.1.2.3.2.1.1
UM	Utility message		4, 5, 20, 21	3.1.2.6.5.3
VS	Vertical status		0	3.1.2.8.2.1

**Table 3-4. Subfield definitions**

<i>Subfield</i>		<i>Field</i>	<i>Reference</i>
<i>Designator</i>	<i>Function</i>		
ACS	Altitude code subfield	ME	3.1.2.8.6.3.1.2
AIS	Aircraft identification subfield	MB	3.1.2.9.1.1
ATS	Altitude type subfield	MB	3.1.2.8.6.8.2
BDS 1	Comm-B data selector subfield 1	MB	3.1.2.6.11.2.1
BDS 2	Comm-B data selector subfield 2	MB	3.1.2.6.11.2.1
IDS	Identifier designator subfield	UM	3.1.2.6.5.3.1
IDS	Interrogator identifier subfield	SD	3.1.2.6.1.4.1 a)
		UM	3.1.2.6.5.3.1
LOS	Lockout subfield	SD	3.1.2.6.1.4.1 d)
LSS	Lockout surveillance subfield	SD	3.1.2.6.1.4.1 g)
MSB	Multisite Comm-B subfield	SD	3.1.2.6.1.4.1 c)
AES	Multisite ELM subfield	SD	3.1.2.6.1.4.1 c)
RCS	Rate control subfield	SD	3.1.2.6.1.4.1 f)
RLS	Reply request subfield	SD	3.1.2.6.1.4.1 e) and g)
RSS	Reservation status subfield	SD	3.1.2.6.1.4.1 c)
SAS	Surface antenna subfield	SD	3.1.2.6.1.4.1 f)
SUS	Squitter capability subfield	MB	3.1.2.6.10.2.2.1
SIC	Surveillance identifier capability	MB	3.1.2.6.10.2.2.1
SIS	Surveillance identifier subfield	SD	3.1.2.6.1.4.1 g)
SRE	Segment request subfield	MC	3.1.2.7.7.2.1
SSS	Surveillance status subfield	ME	3.1.2.8.6.3.1.1
TAS	Transmission acknowledgement subfield	MD	3.1.2.7.4.2.6
TCS	Type control subfield	SD	3.1.2.6.1.4.1 f)
TCS	Tactical message subfield	SD	3.1.2.6.1.4.1 d)
TRS	Transmission rate subfield	MB	3.1.2.8.6.8.1

804.3.1.2.3.3 ERROR PROTECTION

804.3.1.2.3.3.1 Technique. Parity check coding shall be used within Mode S interrogations and replies to provide protection against the occurrence of errors.

804.3.1.2.3.3.1.1 Parity check sequence. A sequence of 24 parity check bits shall be generated by the rule described in 804.3.1.2.3.3.1.2 and shall be incorporated into the field formed by the last 24 bits of all Mode S transmissions. The 24 parity check bits shall be combined with either the address coding or the interrogator identifier coding as described in 804.3.1.2.3.3.2. The resulting combination then forms either the AP (address/parity, 804.3.1.2.3.2.1.3) field or the PI (parity/interrogator identifier, 804.3.1.2.3.2.1.4) field.

804.3.1.2.3.3.1.2 Parity check sequence generation. The sequence of 24 parity bits (p1, p2, . . . , p24) shall be generated from the sequence of information bits (m1, m2, . . . , mk) where k is 32 or 88 for short or long transmissions respectively. This shall be done by means of a code generated by the polynomial:

$$G(x) = 1 + x^3 + x^{10} + x^{12} + x^{13} + x^{14} + x^{15} + x^{16} \\ + x^{17} + x^{18} + x^{19} + x^{20} + x^{21} + x^{22} + x^{23} + x^{24}$$

When by the application of binary polynomial algebra,  $x^{24} [M(x)]$  is divided by  $G(x)$  where the information sequence  $M(x)$  is:

$$m_k + m_{k-1}x + m_{k-2}x^2 + \dots + m_1x^{k-1}$$

The result is a quotient and a remainder  $R(x)$  of degree less than 24. The bit sequence formed by this remainder represents the parity check sequence. Parity bit  $p_i$ , for any  $i$  from 1 to 24, is the coefficient of  $x^{24-i}$  in  $R(x)$ .

804.3.1.2.3.3.2 AP and PI field generation. Different address parity sequences shall be used for the uplink and downlink.

The code used in uplink AP field generation shall be formed as specified below from either the aircraft address (804.3.1.2.4.1.2.3.1.1), the all-call address (804.3.1.2.4.1.2.3.1.2) or the broadcast address (804.3.1.2.4.1.2.3.1.3).

The code used in downlink AP field generation shall be formed directly from the sequence of 24 Mode S address bits ( $a_1, a_2, \dots, a_{24}$ ), where  $a_i$  is the  $i$ -th bit transmitted in the aircraft address (AA) field of an all-call reply (804.3.1.2.5.2.2.2).

The code used in downlink PI field generation shall be formed by a sequence of 24 bits ( $a_1, a_2, \dots, a_{24}$ ), where the first 17 bits are ZEROS, the next three bits are a replica of the code label (CL) field (804.3.1.2.5.2.1.3) and the last four bits are a replica of the interrogator code (IC) field (804.3.1.2.5.2.1.2).

A modified sequence ( $b_1, b_2, \dots, b_{24}$ ) shall be used for uplink AP field generation. Bit  $b_i$  is the coefficient of  $x^{24-i}$  in the polynomial  $G(x)A(x)$ , where:

$$A(x) = a_1x^{23} + a_2x^{22} + \dots + a_{24}$$

and

$G(x)$  is as defined in 804.3.1.2.3.3.1.2.

In the aircraft address  $a_i$  shall be the  $i$ -th bit transmitted in the AA field of an all-call reply. In the all-call and broadcast addresses  $a_i$  shall equal 1 for all values of  $i$ .

804.3.1.2.3.3.2.1 Uplink transmission order. The sequence of bits transmitted in the uplink AP field is:

$$t_{k+1}, t_{k+2} \dots t_{k+24}$$

where the bits are numbered in order of transmission, starting with  $k + 1$ .

In uplink transmissions:

$$t_{k+i} = b_i \oplus p_i$$

where “ $\oplus$ ” prescribes modulo-2 addition:  $i$  equals 1 is the first bit transmitted in the AP field.

804.3.1.2.3.3.2.2 Downlink transmission order. The sequence of bits transmitted in the downlink AP and PI field is:

$$tk + 1, tk + 2 \dots tk + 24$$

Where the bits are numbered in order of transmission, starting with  $k + 1$ . In downlink transmissions:

$$tk + i = ai \ r \ pi$$

Where “r” prescribes modulo-2 addition:  $i$  equals 1 is the first bit transmitted in the AP or PI field.

#### 804.3.1.2.4 GENERAL INTERROGATION-REPLY PROTOCOL

804.3.1.2.4.1 Transponder transaction cycle. A transponder transaction cycle shall begin when the SSR Mode S transponder has recognized an interrogation. The transponder shall then evaluate the interrogation and determine whether it shall be accepted. If accepted, it shall then process the received interrogation and generate a reply, if appropriate. The transaction cycle shall end when:

- a) any one of the necessary conditions for acceptance has not been met, or
- b) an interrogation has been accepted and the transponder has either:
  - 1) Completed the processing of the accepted interrogation if no reply is required, or
  - 2) Completed the transmission of a reply.

A new transponder transaction cycle shall not begin until the previous cycle has ended.

804.3.1.2.4.1.1 Interrogation recognition. SSR Mode S transponders shall be capable of recognizing the following distinct types of interrogations:

- a) Modes A and C;
- b) intermode; and
- c) Mode S.

804.3.1.2.4.1.1.1 Mode A and Mode C interrogation recognition. A Mode A or Mode C interrogation shall be recognized when a P1 - P3 pulse pair meeting the requirements of 804.3.1.1.4 has been received, and the leading edge of a P4 pulse with an amplitude that is greater than a level 6 dB below the amplitude of P3 is not received within the interval from 1.7 to 2.3 microseconds following the leading edge of P3.

If a P1 - P2 suppression pair and a Mode A or Mode C interrogation are recognized simultaneously, the transponder shall be suppressed. An interrogation shall not be recognized as Mode A or Mode C if the transponder is in suppression (3.1.2.4.2). If a Mode A and a Mode C interrogation are recognized simultaneously the transponder shall complete the transaction cycle as if only a Mode C interrogation had been recognized.

804.3.1.2.4.1.1.2 Intermode interrogation recognition. An intermode interrogation shall be recognized when a P1 - P3 -P4 pulse triplet meeting the requirements of 3.1.2.1.5.1 is received. An interrogation shall not be recognized as an intermode interrogation if:

- a) The received amplitude of the pulse in the P4 position is smaller than 6 dB below the amplitude of P3; or
- b) The pulse interval between P3 and P4 is larger than 2.3 microseconds or shorter than 1.7 microseconds; or
- c) The received amplitude of P1 and P3 is between MTL and -45 dBm and the pulse duration of P1 or P3 is less than 0.3 microsecond; or
- d) The transponder is in suppression (804.3.1.2.4.2).

If a P1 - P2 suppression pair and a Mode A or Mode C intermode interrogation are recognized simultaneously the transponder shall be suppressed.

804.3.1.2.4.1.1.3 Mode S interrogation recognition. A Mode S interrogation shall be recognized when a P6 pulse is received with a sync phase reversal within the interval from 1.20 to 1.30 microseconds following the leading edge of P6. A Mode S interrogation shall not be recognized if a sync phase reversal is not received within the interval from 1.05 to 1.45 microseconds following the leading edge of P6.

804.3.1.2.4.1.2 Interrogation acceptance. Recognition according to 804.3.1.2.4.1 shall be a prerequisite for acceptance of any interrogation.

804.3.1.2.4.1.2.1 Mode A and Mode C interrogation acceptance. Mode A and Mode C interrogations shall be accepted when recognized (804.3.1.2.4.1.1.1).

804.3.1.2.4.1.2.2 Intermode interrogation acceptance

804.3.1.2.4.1.2.2.1 Mode A/C/S all-call interrogation acceptance. A Mode A/C/S all-call interrogation shall be accepted if the trailing edge of P4 is received within 3.45 to 3.75 microseconds following the leading edge of P3 and no lockout condition (804.3.1.2.6.9) prevents acceptance. A Mode A/C/S all-call shall not be accepted if the trailing edge of P4 is received earlier than 3.3 or later than 4.2 microseconds following the leading edge of P3, or if a lockout condition (804.3.1.2.6.9) prevents acceptance.

804.3.1.2.4.1.2.2.2 Mode A/C-only all-call interrogation acceptance. A Mode A/C-only all-call interrogation shall not be accepted by a Mode S transponder.

804.3.1.2.4.1.2.3 Mode S interrogation acceptance. A Mode S interrogation shall only be accepted if:

- a) The transponder is capable of processing the uplink format (UF) of the interrogation (804.3.1.2.3.2.1.1);
- b) the address of the interrogation matches one of the addresses as defined in 804.3.1.2.4.1.2.3.1 implying that parity is established, as defined in 804.3.1.2.3.3;
- c) No all-call lockout condition applies, as defined in 804.3.1.2.6.9; and
- d) The transponder is capable of processing the uplinked data and presenting it at an output interface as prescribed in 804.3.1.2.10.5.2.2.1.

804.3.1.2.4.1.2.3.1 Addresses. Mode S interrogations shall contain either:

- a) Aircraft address; or
- b) The all-call address; or
- c) The broadcast address.

804.3.1.2.4.1.2.3.1.1 Aircraft address. If the aircraft's address is identical to the address extracted from a received interrogation according to the procedure of 804.3.1.2.3.3.2 and 804.3.1.2.3.3.2.1, the extracted address shall be considered correct for purposes of Mode S interrogation acceptance.

804.3.1.2.4.1.2.3.1.2 All-call address. A Mode S-only all-call interrogation (uplink format UF = 11) shall contain an address, designated the all-call address, consisting of twenty-four consecutive ONEs. If the all-call address is extracted from a received interrogation with format UF = 11 according to the procedure of 804.3.1.2.3.3.2 and 804.3.1.2.3.3.2.1, the address shall be considered correct for Mode S-only all-call interrogation acceptance.

804.3.1.2.4.1.2.3.1.3 Broadcast address. To broadcast a message to all Mode S transponders within the interrogator beam, a Mode S interrogation uplink format 20 or 21 shall be used and an address of twenty-four consecutive ONEs shall be substituted for the aircraft address. If the UF code is 20 or 21 and this broadcast address is extracted from a received interrogation according to the procedure of 804.3.1.2.3.3.2 and 804.3.1.2.3.3.2.1, the address shall be considered correct for Mode S broadcast interrogation acceptance.

804.3.1.2.4.1.3 Transponder replies. Mode S transponders shall transmit the following reply types:

- a) Mode A and Mode C replies; and
- b) Mode S replies.

804.3.1.2.4.1.3.1 Mode A and Mode C replies. A Mode A (Mode C) reply shall be transmitted as specified in 804.3.1.1.6 when a Mode A (Mode C) interrogation has been accepted.

804.3.1.2.4.1.3.2 Mode S replies. Replies to other than Mode A and Mode C interrogations shall be Mode S replies.

804.3.1.2.4.1.3.2.1 Replies to intermode interrogations. A Mode S reply with downlink format 11 shall be transmitted in accordance with the provisions of 804.3.1.2.5.2.2 when a Mode A/C/S all-call interrogation has been accepted.

804.3.1.2.4.1.3.2.2 Replies to Mode S interrogations. The information content of a Mode S reply shall reflect the conditions existing in the transponder after completion of all processing of the interrogation eliciting that reply. The correspondence between uplink and downlink formats shall be as summarized in Table 3-5.

**Table 3-5. Interrogation — reply protocol summary**

<i>Interrogation UF</i>	<i>Special conditions</i>	<i>Reply DF</i>
0	RL (3.1.2.8.1.2) equals 0 RL (3.1.2.8.1.2) equals 1	0 16
4	RR (3.1.2.6.1.2) less than 16 RR (3.1.2.6.1.2) equal to or greater than 16	4 20
5	RR (3.1.2.6.1.2) less than 16 RR (3.1.2.6.1.2) equal to or greater than 16	5 21
11	Transponder locked out to interrogator code, IC (3.1.2.5.2.1.2) Stochastic reply test fails (3.1.2.5.4) Otherwise	No reply No reply 11
20	RR (3.1.2.6.1.2) less than 16 RR (3.1.2.6.1.2) equal to or greater than 16 AP contains broadcast address (3.1.2.4.1.2.3.1.3)	4 20 No reply
21	RR (3.1.2.6.1.2) less than 16 RR (3.1.2.6.1.2) equal to or greater than 16 AP contains broadcast address (3.1.2.4.1.2.3.1.3)	5 21 No reply
24	RC (3.1.2.7.1.1) equals 0 or 1 RC (3.1.2.7.1.1) equals 2 or 3	No reply 24

804.3.1.2.4.1.3.2.2.1 Replies to SSR Mode S-only all-call interrogations. The downlink format of the reply to a Mode S-only all-call interrogation (if required) shall be DF = 11. The reply content and rules for determining the requirement to reply shall be as defined in 804.3.1.2.5.

804.3.1.2.4.1.3.2.2.2 Replies to surveillance and standard length communications interrogations. A Mode S reply shall be transmitted when a Mode S interrogation with UF = 4, 5, 20 or 21 and an aircraft address has been accepted. The contents of these interrogations and replies shall be as defined in 804.3.1.2.6.

804.3.1.2.4.1.3.2.2.3 Replies to extended length communications interrogations. A series of Mode S replies ranging in number from 0 to 16 shall be transmitted when a Mode S interrogation with UF = 24 has been accepted. The downlink format of the reply (if any) shall be DF = 24. Protocols defining the number and content of the replies shall be as defined in 804.3.1.2.7.

804.3.1.2.4.1.3.2.2.4 Replies to air-air surveillance interrogations. A Mode S reply shall be transmitted when a Mode S interrogation with UF = 0 and an aircraft address has been accepted. The contents of these interrogations and replies shall be as defined in 804.3.1.2.8.

804.3.1.2.4.2 SUPPRESSION

804.3.1.2.4.2.1 Effects of suppression. A transponder in suppression (804.3.1.1.7.4) shall not recognize Mode A, Mode C or intermode interrogations if either the P1 pulse alone or both the P1 and P3 pulses of the interrogation are received during the suppression interval. Suppression shall not affect the recognition of, acceptance of, or replies to Mode S interrogations.

804.3.1.2.4.2.2 Suppression pairs. The two-pulse Mode A/C suppression pair defined in 804.3.1.1.7.4.1 shall initiate suppression in a Mode S transponder regardless of the position of the pulse pair in a group of pulses, provided the transponder is not already suppressed or in a transaction cycle.

804.3.1.2.5 INTERMODE AND MODE S ALL-CALL TRANSACTIONS

804.3.1.2.5.2.1 Mode S-only all-call interrogation, uplink format 11

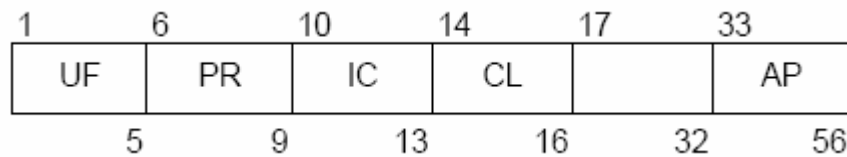

The format of this interrogation shall consist of these fields:

Field	Reference
UF uplink format	804.3.1.2.3.2.1.1
PR probability of reply	804.3.1.2.5.2.1.1
IC interrogator code	804.3.1.2.5.2.1.2
CL code label	804.3.1.2.5.2.1.3
Spare — 16 bits	
AP address/parity	804.3.1.2.3.2.1.3

804.3.1.2.5.2.1.1 PR: Probability of reply. This 4-bit (6-9) uplink field shall contain commands to the transponder specifying the probability of reply to that interrogation (804.3.1.2.5.4). Codes are as follows:

0	signifies reply with probability of 1
1	signifies reply with probability of 1/2
2	signifies reply with probability of 1/4
3	signifies reply with probability of 1/8
4	signifies reply with probability of 1/16
5, 6, 7	not assigned
8	signifies disregard lockout, reply with probability of 1
9	signifies disregard lockout, reply with probability of 1/2
10	signifies disregard lockout, reply with probability of 1/4
11	signifies disregard lockout, reply with probability of 1/8
12	signifies disregard lockout, reply with probability of 1/16
13, 14, 15	not assigned.

804.3.1.2.5.2.1.2 IC: Interrogator code. This 4-bit (10-13) uplink field shall contain either the 4-bit interrogator identifier code (804.3.1.2.5.2.1.2.1) or the lower 4 bits of the 6-bit surveillance identifier code (804.3.1.2.5.2.1.2.2) depending on the value of the CL field (804.3.1.2.5.2.1.3).



804.3.1.2.5.2.1.2.3 II: Interrogator identifier. This 4-bit value shall define an interrogator identifier (II) code. These II codes shall be assigned to interrogators in the range from 0 to 15. The II code value of 0 shall only be used in conjunction with acquisition based on lockout override (804.3.1.2.5.2.1.4 and 804.3.1.2.5.2.1.5).

804.3.1.2.5.2.1.2.4 SI: Surveillance identifier. This 6-bit value shall define a surveillance identifier (SI) code. These SI codes shall be assigned to interrogators in the range from 1 to 63. The SI code value of 0 shall not be used. The SI codes shall be used with the multisite lockout protocols (804.3.1.2.6.9.1). The SI codes shall not be used with the multisite communications protocols (804.3.1.2.6.11.3.2, 804.3.1.2.7.4 or 804.3.1.2.7.7).

804.3.1.2.5.2.1.3 CL: Code label. This 3-bit (14-16) uplink field shall define the contents of the IC field.

Coding	(in binary)
000	signifies that the IC field contains the II code
001	signifies that the IC field contains SI codes 1 to 15
010	signifies that the IC field contains SI codes 16 to 31
011	signifies that the IC field contains SI codes 32 to 47
100	signifies that the IC field contains SI codes 48 to 63

The other values of the CL field shall not be used.

804.3.1.2.5.2.1.3.1 Surveillance identifier (SI) code capability report. Transponders which process the SI codes (804.3.1.2.5.2.1.2.2) shall report this capability by setting bit 35 to 1 in the surveillance identifier capability (SIC) subfield of the MB field of the data link capability report (804.3.1.2.6.10.2.2).

804.3.1.2.5.2.1.4 Operation based on lockout override for an interrogator without an assigned interrogator code.

804.3.1.2.5.2.1.4.1 Maximum Mode S-only all-call interrogation rate. The maximum rate of Mode S-only all-call interrogations made by an interrogator using acquisition based on lockout override shall depend on the reply probability as follows:

- a) For a reply probability equal to 1.0:  
The smaller of 3 interrogations per 3 dB beam dwell or 30 interrogations per second;
- b) For a reply probability equal to 0.5:  
The smaller of 5 interrogations per 3 dB beam dwell or 60 interrogations per second;  
and
- c) For a reply probability equal to 0.25 or less:  
The smaller of 10 interrogations per 3 dB beam dwell or 125 interrogations per second.

804.3.1.2.5.2.1.4.2 Field content for a selectively addressed interrogation. Selectively addressed interrogations used in connection with acquisition using lockout override shall have interrogation field contents restricted as follows:

UF = 4, 5, 20 or 21  
PC = 0  
RR = 16 if RRS = 0  
DI = 7  
IIS = 0  
LOS = 0 except as specified in 3.1.2.5.2.1.5  
TMS = 0

804.3.1.2.5.2.1.5.1 Lockout within a beam dwell. When II equals 0 lockout is used to supplement the acquisition technique of 804.3.1.2.5.2.1.4, all aircraft within the beam dwell of the aircraft being acquired should be commanded to lockout to II equals 0, not just those in the garble zone.

804.3.1.2.5.2.1.5.2 Duration of lockout. Interrogators performing supplementary acquisition using II equals 0 (in connection with the technique of 804.3.1.2.5.2.1.4) should perform acquisition by transmitting a lockout command for no more than a single scan to each of the acquired aircraft in the beam dwell containing the garble zone.

804.3.1.2.5.2 Mode S only all-call interrogations with II = 0 for the purpose of supplementary acquisition should take place over no more than two consecutive scans.

804.3.1.2.5.2.2 All-call reply, downlink format 11

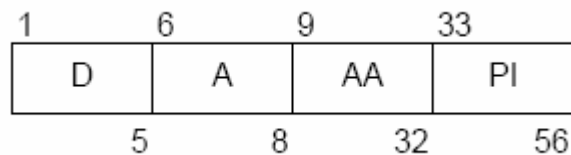

The reply to the Mode S-only all-call or the Mode A/C/S all-call interrogation shall be the Mode S all-call reply, downlink format 11. The format of this reply shall consist of these fields:

Field	Reference
DF downlink format	804.3.1.2.3.2.1.2
CA capability	804.3.1.2.5.2.2.1
AA address announced	804.3.1.2.5.2.2.2
PI parity/interrogator identifier	804.3.1.2.3.2.1.4

804.3.1.2.5.2.2.1 CA: Capability. This 3-bit (6-8) downlink field shall contain an encoded definition of the communications capability of the transponder and shall be used in the all-call reply format (DF = 11).

**Coding**

0	signifies no communications capability (surveillance only), and no ability to set CA code 7 and either airborne or on the ground
1	reserved
2	reserved
3	reserved
4	signifies at least Comm-A and Comm-B capability and ability to set CA code 7 and on the ground
5	signifies at least Comm-A and Comm-B capability and ability to set CA code 7 and airborne
6	signifies at least Comm-A and Comm-B capability and ability to set CA code 7 and either airborne or on the ground
7	signifies the DR field is not equal to 0 or the FS field equals 2, 3, 4 or 5, and either airborne or on the ground

When the conditions for CA code 7 are not satisfied, installations that have communications capability but do not have automatic means to set the on-the-ground condition shall use CA code 6. Aircraft with

automatic on the-ground determination shall use CA code 4 or 5. Data link capability reports (804.3.1.2.6.10.2.2) shall be available from aircraft installations that set CA code 4, 5, 6 or 7.

804.3.1.2.5.2.2.2 AA: Address announced. This 24-bit (9-32) downlink field shall contain the aircraft address which provides unambiguous identification of the aircraft.

804.3.1.2.5.3 Lockout protocol. The all-call lockout protocol defined in 804.3.1.2.6.9 shall be used by the interrogator with respect to an aircraft once the address of that specific aircraft has been acquired by an interrogator.

804.3.1.2.5.4 Stochastic all-call protocol. The transponder shall execute a random process upon acceptance of a Mode S-only all-call with a PR code equal to 1 to 4 or 9 to 12. A decision to reply shall be made in accordance with the probability specified in the interrogation. A transponder shall not reply if a PR code equal to 5, 6, 7, 13, 14 or 15 is received (804.3.1.2.5.2.1.1).

804.3.1.2.6 ADDRESSED SURVEILLANCE AND STANDARD LENGTH COMMUNICATION TRANSACTIONS

804.3.1.2.6.1 SURVEILLANCE, ALTITUDE REQUEST, UPLINK FORMAT 4



The format of this interrogation shall consist of these fields:

Field	Reference
UF uplink format	804.3.1.2.3.2.1.1
PC protocol	804.3.1.2.6.1.1
RR reply request	804.3.1.2.6.1.2
DI designator identification	804.3.1.2.6.1.3
SD special designator	804.3.1.2.6.1.4
AP address/parity	804.3.1.2.3.2.1.3

804.3.1.2.6.1.1 PC: Protocol. This 3-bit, (6-8) uplink field shall contain operating commands to the transponder. The PC field shall be ignored for the processing of surveillance or Comm-A interrogations containing DI = 3 (804.3.1.2.6.1.4.1).

Coding

0	signifies no action
1	signifies non-selective all-call lockout (804.3.1.2.6.9.2)
2	not assigned
3	not assigned
4	signifies close out Comm-B (804.3.1.2.6.11.3.2.3)
5	signifies close out uplink ELM (804.3.1.2.7.4.2.8)
6	signifies close out downlink ELM (804.3.1.2.7.7.3)
7	not assigned.

804.3.1.2.6.1.2 RR: Reply request. This 5-bit, (9-13) uplink field shall command the length and content of a requested reply. The last four bits of the 5-bit RR code, transformed into their decimal equivalent, shall designate

Coding

- RR = 0-15 shall be used to request a reply with surveillance format (DF = 4 or 5);
- RR = 16-31 shall be used to request a reply with Comm-B format (DF = 20 or 21);
- RR = 16 shall be used to request transmission of an air-initiated Comm-B according to 804.3.1.2.6.11.3;
- RR = 17 shall be used to request a data link capability report according to 804.3.1.2.6.10.2.2;
- RR = 18 shall be used to request aircraft identification according to 804.3.1.2.9;
- 19-31 are not assigned in section 3.1.

804.3.1.2.6.1.3 DI: Designator identification. This 3-bit (14-16) uplink field shall identify the structure of the SD field (804.3.1.2.6.1.4).

Coding

- 0 signifies SD not assigned except for IIS
- 1 signifies SD contains multisite and communications control information
- 2 signifies SD contains control data for extended squitter
- 3 signifies SD contains SI multisite lockout, broadcast and GICB control information
- 4-6 signifies SD not assigned
- 7 signifies SD contains extended data readout request, multisite and communications control information.

804.3.1.2.6.1.4 SD: Special designator. This 16-bit (17-32) uplink field shall contain control codes which depend on the coding in the DI field.

*DI CODE*

*SD FIELD STRUCTURE*

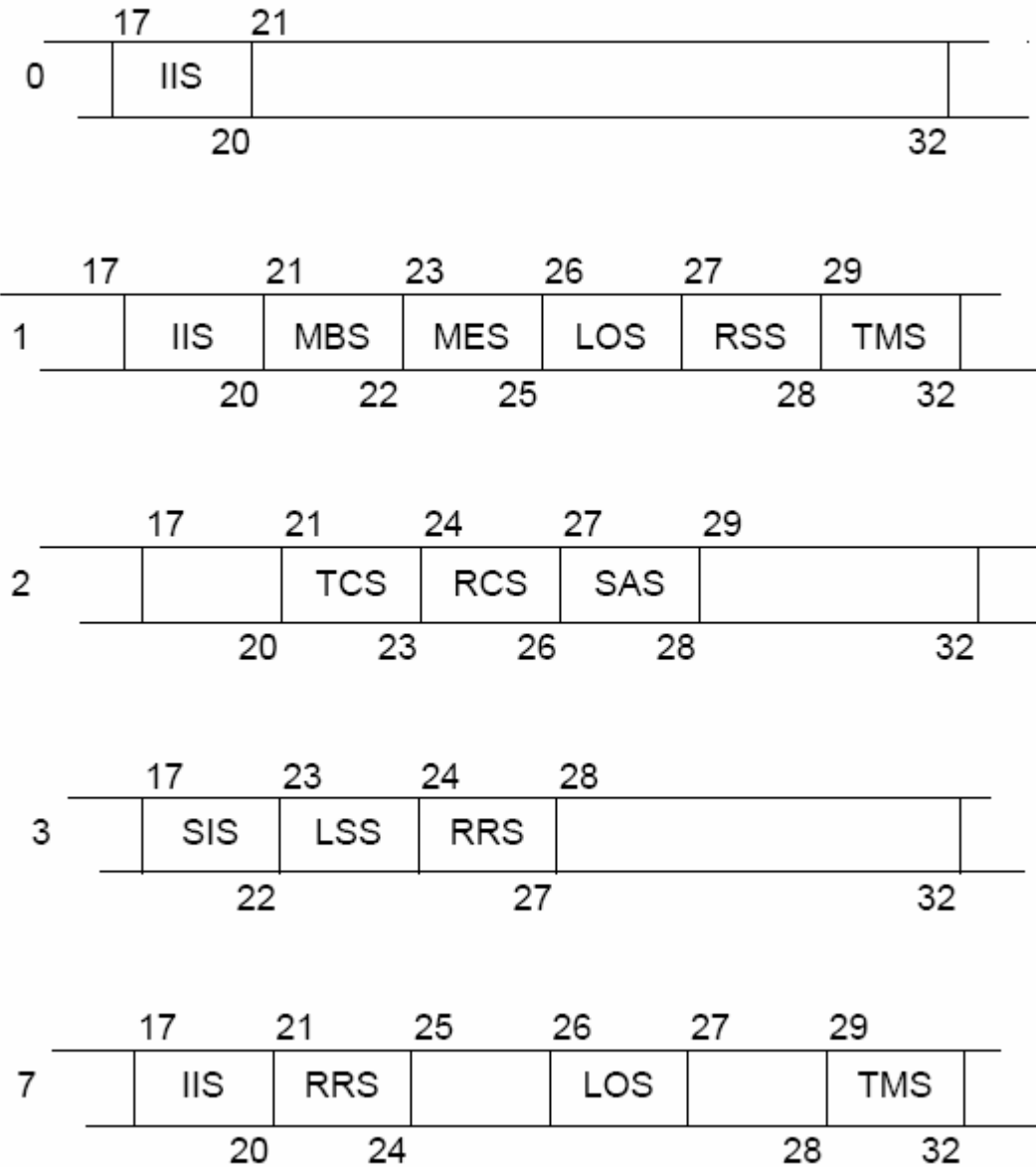

804.3.1.2.6.1.4.1

Subfields in SD. The SD field shall contain information as follows:

- a) If DI = 0, 1 or 7:  
 IIS, the 4-bit (17-20) interrogator identifier subfield shall contain an assigned identifier code of the interrogator (804.3.1.2.5.2.1.2).
- b) If DI = 0:  
 Bits 21-32 are not assigned.
- c) If DI = 1:  
 MBS, the 2-bit (21, 22) multisite Comm-B subfield shall have the following codes:  
 0 signifies no Comm-B action

1 signifies air-initiated Comm-B reservation request (804.3.1.2.6.11.3.1)

2 signifies Comm-B closeout (804.3.1.2.6.11.3.2.3)

3 not assigned.

MES, the 3-bit (23-25) multisite ELM subfield shall contain reservation and closeout commands for ELM as follows:

0 signifies no ELM action

1 signifies uplink ELM reservation request (804.3.1.2.7.4.1)

2 signifies uplink ELM closeout (804.3.1.2.7.4.2.8)

3 signifies downlink ELM reservation request (804.3.1.2.7.7.1.1)

4 signifies downlink ELM closeout (804.3.1.2.7.7.3)

5 signifies uplink ELM reservation request and downlink ELM closeout

6 signifies uplink ELM closeout and downlink ELM reservation request

7 signifies uplink ELM and downlink ELM closeouts.

RSS, the 2-bit (27, 28) reservation status subfield shall request the transponder to report its reservation status in the UM field. The following codes have been assigned:

0 signifies no request

1 signifies report Comm-B reservation status in UM

2 signifies report uplink ELM reservation status in UM

3 signifies report downlink ELM reservation status in UM.

d) If DI = 1 or 7:

LOS, the 1-bit (26) lockout subfield, if set to 1, shall signify a multisite lockout command from the interrogator indicated in IIS. LOS set to 0, shall be used to signify that no change in lockout state is commanded.

TMS, the 4-bit (29-32) tactical message subfield shall contain communications control information used by the data link avionics.

e) If DI = 7:

RRS, the 4-bit (21-24) reply request subfield in SD shall give the BDS2 code of a requested Comm-B reply.

Bits 25, 27 and 28 are not assigned.

f) If DI = 2:

TCS, the 3-bit (21-23) type control subfield in SD shall control the position type used by the transponder.

The following codes have been assigned:

0 signifies no position type command

1 signifies use surface position type for the next 15 seconds

2 signifies use surface position type for the next 60 seconds

3 signifies cancel surface type command

4-7 not assigned.

RCS, the 3-bit (24-26) rate control subfield in SD shall control the squitter rate of the transponder when it is reporting the surface format. This subfield shall have no effect on the transponder squitter rate when it is reporting the airborne position type. The following codes have been assigned:

0 signifies no surface squitter rate command

1 signifies report high surface squitter rate for 60 seconds

2 signifies report low surface squitter rate for 60 seconds

3 signifies suppress all surface squitters for 60 seconds  
 4 signifies suppress all surface squitters for 120 seconds  
 5-7 not assigned.

SAS, the 2-bit (27-28) surface antenna subfield in SD shall control the transponder diversity antenna that is used for the extended squitter when it is reporting the surface format. This subfield shall have no effect on the transponder diversity antenna selection when it is reporting the airborne position type. The following codes have been assigned:

0 signifies no antenna command  
 1 signifies alternate top and bottom antennas for 120 seconds  
 2 signifies use bottom antenna for 120 seconds  
 3 signifies return to the default.

g) If DI = 3:  
 SIS, the 6-bit (17-22) surveillance identifier subfield in SD shall contain an assigned surveillance identifier code of the interrogator (804.3.1.2.5.2.1.2.2).

LSS, the 1-bit (23) lockout surveillance subfield, if set to 1, shall signify a multisite lockout command from the interrogator indicated in SIS. If set to 0, LSS shall signify that no change in lockout state is commanded.

RRS, the 4-bit (24-27) reply request subfield in SD shall contain the BDS2 code of a requested GICB register.

Bits 28 to 32 are not assigned.

804.3.1.2.6.1.5 PC and SD field processing. When DI = 1, PC field processing shall be completed before processing the SD field.

804.3.1.2.6.2 COMM-A ALTITUDE REQUEST, UPLINK FORMAT 20

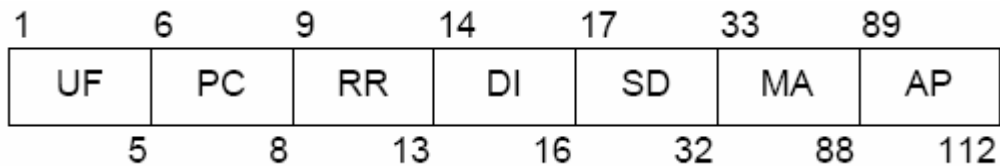

The format of this interrogation shall consist of these fields:

Field	Reference
UF uplink format	804.3.1.2.3.2.1.1
PC protocol	804.3.1.2.6.1.1
RR reply request	804.3.1.2.6.1.2
DI designator identification	804.3.1.2.6.1.3
SD special designator	804.3.1.2.6.1.4
MA message, Comm-A	804.3.1.2.6.2.1
AP address/parity	804.3.1.2.3.2.1.3

804.3.1.2.6.2.1 MA: Message, Comm-A. This 56-bit (33-88) field shall contain a data link message to the aircraft.

804.3.1.2.6.3 SURVEILLANCE IDENTITY REQUEST, UPLINK FORMAT 5

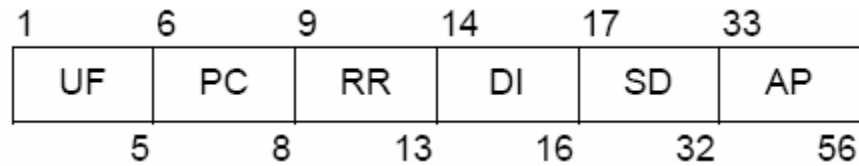

The format of this interrogation shall consist of these fields:

Field	Reference
UF uplink format	804.3.1.2.3.2.1.1
PC protocol	804.3.1.2.6.1.1
RR reply request	804.3.1.2.6.1.2
DI designator identification	804.3.1.2.6.1.3
SD special designator	804.3.1.2.6.1.4
AP address/parity	804.3.1.2.3.2.1.3

804.3.1.2.6.4 COMM-A IDENTITY REQUEST, UPLINK FORMAT 21

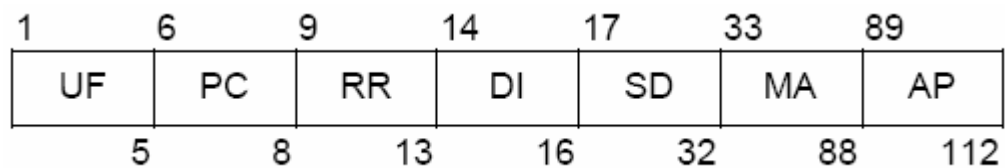

The format of this interrogation shall consist of these fields:

Field	Reference
UF uplink format	804.3.1.2.3.2.1.1
PC protocol	804.3.1.2.6.1.1
RR reply request	804.3.1.2.6.1.2
DI designator identification	804.3.1.2.6.1.3
SD special designator	804.3.1.2.6.1.4
MA message, Comm-A	804.3.1.2.6.2.1
AP address/parity	804.3.1.2.3.2.1.3

804.3.1.2.6.5 Surveillance altitude reply, downlink format 4

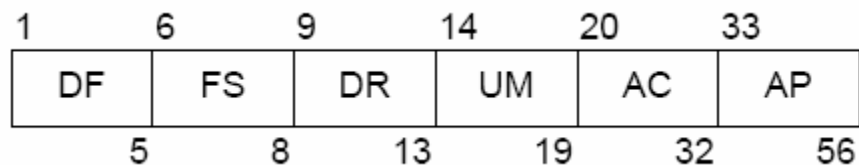

This reply shall be generated in response to an interrogation UF 4 or 20 with an RR field value less than 16. The format of this reply shall consist of these fields:

Field	Reference
DF downlink format	804.3.1.2.3.2.1.2



FS flight status	804.3.1.2.6.5.1
DR downlink request	804.3.1.2.6.5.2
UM utility message	804.3.1.2.6.5.3
AC altitude code	804.3.1.2.6.5.4
AP address/parity	804.3.1.2.3.2.1.3

804.3.1.2.6.5.1 FS: Flight status. This 3-bit (6-8) downlink field shall contain the following information:

Coding

0	signifies no alert and no SPI, aircraft is airborne
1	signifies no alert and no SPI, aircraft is on the ground
2	signifies alert, no SPI, aircraft is airborne
3	signifies alert, no SPI, aircraft is on the ground
4	signifies alert and SPI, aircraft is airborne or on the ground
5	signifies no alert and SPI, aircraft is airborne or on the ground
6	not assigned
7	not assigned

804.3.1.2.6.5.2 DR: Downlink request. This 5-bit (9-13) downlink field shall contain requests to downlink information.

Coding

0	signifies no downlink request
1	signifies request to send Comm-B message
2	reserved for ACAS
3	reserved for ACAS
4	signifies Comm-B broadcast message 1 available
5	signifies Comm-B broadcast message 2 available
6	reserved for ACAS
7	reserved for ACAS
8-15	not assigned
16-31	see downlink ELM protocol (804.3.1.2.7.7.1)

Codes 1-15 shall take precedence over codes 16-31.

804.3.1.2.6.5.3 UM: Utility message. This 6-bit (14-19) downlink field shall contain transponder communications status information as specified in 804.3.1.2.6.1.4.1 and 804.3.1.2.6.5.3.1.

804.3.1.2.6.5.3.1 Subfields in UM for multisite protocols

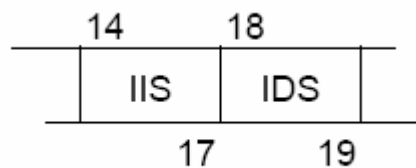

The following subfields shall be inserted by the transponder into the UM field of the reply if a surveillance or Comm-A interrogation (UF equals 4, 5, 20, 21) contains DI = 1 and RSS other than 0:

IIS: The 4-bit (14-17) interrogator identifier subfield reports the identifier of the interrogator that is reserved for multisite communications.

IDS: The 2-bit (18, 19) identifier designator subfield reports the type of reservation made by the interrogator identified in IIS.

Assigned coding is:

- 0 signifies no information
- 1 signifies IIS contains Comm-B II code
- 2 signifies IIS contains Comm-C II code
- 3 signifies IIS contains Comm-D II code.

804.3.1.2.6.5.3.2 Multisite reservation status. The interrogator identifier of the ground station currently reserved for multisite Comm-B delivery (3.1.2.6.11.3.1) shall be transmitted in the IIS subfield together with code 1 in the IDS subfield if the UM content is not specified by the interrogation (when DI = 0 or 7, or when DI = 1 and RSS = 0).

The interrogator identifier of the ground station currently reserved for downlink ELM delivery (804.3.1.2.7.6.1), if any, shall be transmitted in the IIS subfield together with code 3 in the IDS subfield if the UM content is not specified by the interrogation and there is no current Comm-B reservation.

804.3.1.2.6.5.4 AC: Altitude code. This 13-bit (20-32) field shall contain altitude coded as follows:

- a) Bit 26 is designated as the M bit, and shall be 0 if the altitude is reported in feet. M be reserved to indicate that the altitude reporting is in metric units.
- b) If M equals 0, then bit 28 is designated as the Q bit. Q equals 0 shall be used to indicate that the altitude is reported in 100-foot increments. Q equals 1 shall be used to indicate that the altitude is reported in 25- foot increments.
- c) If the M bit (bit 26) and the Q bit (bit 28) equal 0, the altitude shall be coded according to the pattern for Mode C replies of 3.1.1.7.12.2.3. Starting with bit 20 the sequence shall be C1, A1, C2, A2, C4, A4, ZERO, B1, ZERO, B2, D2, B4, D4.
- d) If the M bit equals 0 and the Q bit equals 1, the 11-bit field represented by bits 20 to 25, 27 and 29 to 32 shall represent a binary coded field with a least significant bit (LSB) of 25 ft. The binary value of the positive decimal integer “N” shall be encoded to report pressure-altitude in the range [(25 N — 1 000) plus or minus 12.5 ft]. The coding of 3.1.1.7.12.2.3 shall be used to report pressure-altitude above 50 187.5 ft.
- e) If the M bit equals 1, the 12-bit field represented by bits 20 to 25 and 27 to 31 shall be reserved for encoding altitude in metric units.
- f) 0 shall be transmitted in each of the 13 bits of the AC field if altitude information is not available.

804.3.1.2.6.6 COMM-B ALTITUDE REPLY, DOWNLINK FORMAT 20

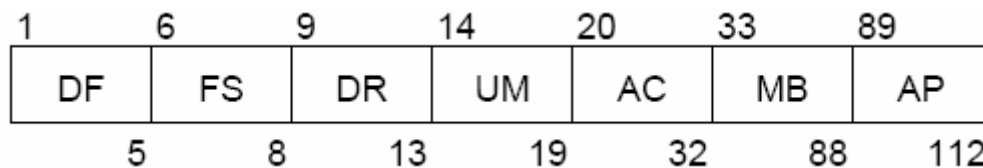

This reply shall be generated in response to an interrogation UF 4 or 20 with an RR field value greater than 15.

The format of this reply shall consist of these fields:

Field	Reference
DF downlink format	804.3.1.2.3.2.1.2
FS flight status	804.3.1.2.6.5.1
DR downlink request	804.3.1.2.6.5.2
UM utility message	804.3.1.2.6.5.3
AC altitude code	804.3.1.2.6.5.4
MB message, Comm-B	804.3.1.2.6.6.1
AP address/parity	804.3.1.2.3.2.1.3

804.3.1.2.6.6.1 MB: Message, Comm-B. This 56-bit (33-88) downlink field shall be used to transmit data link messages to the ground.

804.3.1.2.6.7 SURVEILLANCE IDENTITY REPLY, DOWNLINK FORMAT 5

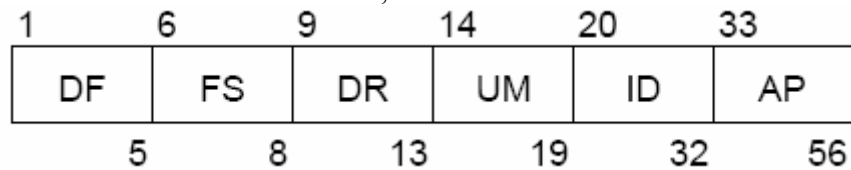

This reply shall be generated in response to an interrogation UF 5 or 21 with an RR field value less than 16. The format of this reply shall consist of these fields:

Field	Reference
DF downlink format	804.3.1.2.3.2.1.2
FS flight status	804.3.1.2.6.5.1
DR downlink request	804.3.1.2.6.5.2
UM utility message	804.3.1.2.6.5.3
ID identity	804.3.1.2.6.7.1
AP address/parity	804.3.1.2.3.2.1.3

804.3.1.2.6.7.1 ID: Identity (Mode A code). This 13-bit (20-32) field shall contain aircraft identity code, in accordance with the pattern for Mode A replies in 3.1.1.6. Starting with bit 20, the sequence shall be C1, A1,C2, A2, C4, A4, ZERO, B1, D1, B2, D2, B4, D4.

804.3.1.2.6.8 COMM-B IDENTITY REPLY, DOWNLINK FORMAT 21

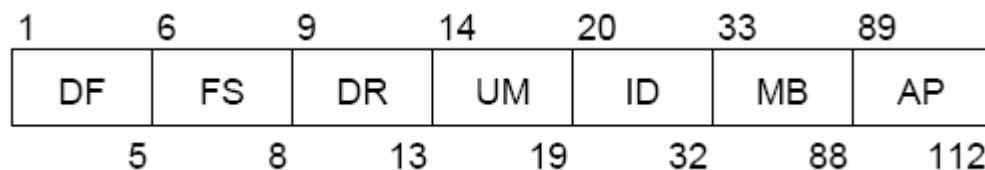

This reply shall be generated in response to an interrogation UF 5 or 21 with an RR field value greater than 15.

The format of this reply shall consist of these fields:

Field	Reference
DF downlink format	804.3.1.2.3.2.1.2
FS flight status	804.3.1.2.6.5.1

DR downlink request	804.3.1.2.6.5.2
UM utility message	804.3.1.2.6.5.3
ID identity	804.3.1.2.6.7.1
MB message, Comm-B	804.3.1.2.6.6.1
AP address/parity	804.3.1.2.3.2.1.3

#### 804.3.1.2.6.9 LOCKOUT PROTOCOLS

##### 804.3.1.2.6.9.1 Multisite all-call lockout

804.3.1.2.6.9.1.1 The multisite lockout command shall be transmitted in the SD field (804.3.1.2.6.1.4.1). A lockout command for an II code shall be transmitted in an SD with DI = 1 or DI = 7. An II lockout command shall be indicated by LOS code equals 1 and the presence of a non-zero interrogator identifier in the IIS subfield of SD.

A lockout command for an SI code shall be transmitted in an SD with DI = 3. SI lockout shall be indicated by LSS equals 1 and the presence of a non-zero interrogator identifier in the SIS subfield of SD. After a transponder has accepted an interrogation containing a multisite lockout command, that transponder shall commence to lock out (i.e. not accept) any Mode S-only all-call interrogation which includes the identifier of the interrogator that commanded the lockout. The lockout shall persist for an interval TL (804.3.1.2.10.3.9) after the last acceptance of an interrogation containing the multisite lockout command. Multisite lockout shall not prevent acceptance of a Mode S-only all-call interrogation containing PR codes 8 to 12. If a lockout command (LOS = 1) is received together with IIS = 0, it shall be interpreted as a non-selective all-call lockout (804.3.1.2.6.9.2).

##### 804.3.1.2.6.9.2 Non-selective all-call lockout

On acceptance of an interrogation containing code 1 in the PC field, a transponder shall commence to lock out (i.e. not accept) two types of all-call interrogations:

- a) The Mode S-only all-call (UF = 11), with II equals 0; and
- b) The Mode A/C/S all-call of 804.3.1.2.1.5.1.1.

This lockout condition shall persist for an interval TD (3.1.2.10.3.9) after the last receipt of the command. Nonselective lockout shall not prevent acceptance of a Mode S-only all-call interrogation containing PR codes 8 to 12.

#### 804.3.1.2.6.10 BASIC DATA PROTOCOLS

804.3.1.2.6.10.1 Flight status protocol. Flight status shall be reported in the FS field (804.3.1.2.6.5.1).

804.3.1.2.6.10.1.1 Alert. An alert condition shall be reported in the FS field if the Mode A identity code transmitted in Mode A replies and in downlink formats DF equals 5 and DF equals 21 are changed by the pilot.

804.3.1.2.6.10.1.1.1 Permanent alert condition. The alert condition shall be maintained if the Mode A identity code is changed to 7500, 7600 or 7700.

804.3.1.2.6.10.1.1.2 Temporary alert condition. The alert condition shall be temporary and shall cancel itself after TC seconds if the Mode A identity code is changed to a value other than those listed in 804.3.1.2.6.10.1.1.1.

804.3.1.2.6.10.1.1.3 Termination of the permanent alert condition. The permanent alert condition shall be terminated and replaced by a temporary alert condition when the Mode A identity code is set to a value other than 7500, 7600 or 7700.

804.3.1.2.6.10.1.2 Ground report. The on-the-ground status of the aircraft shall be reported in the FS field and the VS field (3.1.2.8.2.1). If a means for indicating the on-the-ground condition is not available at the transponder data interface (3.1.2.10.5.1.3), the FS and VS codes shall indicate that the aircraft is airborne.

804.3.1.2.6.10.1.3 Special position identification (SPI). An equivalent of the SPI pulse shall be transmitted by Mode S transponders in the FS field and the surveillance status subfield (SSS) when manually activated. This pulse shall be transmitted for TI seconds after initiation (804.3.1.1.6.3, 804.3.1.1.7.13 and 804.3.1.2.8.6.3.1.1).

#### 804.3.1.2.6.10.2 Capability reporting protocol

804.3.1.2.6.10.2.1 Capability report. The 3-bit CA field, contained in the all-call reply, DF equals 11, shall report the basic capability of the Mode S transponder as described in 804.3.1.2.5.2.2.1.

804.3.1.2.6.10.2.2 Data link capability report. The data link capability report shall provide the interrogator with a description of the data link capability of the Mode S installation. The report shall be obtained by a groundinitiated Comm-B reply in response to an interrogation containing RR equals 17 and DI is not equal to 7 or DI equals 7 and RRS equals 0 (804.3.1.2.6.11.2).

804.3.1.2.6.10.2.2.1 Subfields in MB for data link capability report. The subfields within the MB field of all data link capability reports shall be: (804.3.1.2.6.11.2.1)

BDS1 A value of 1 shall be inserted in this 4-bit (33-36) subfield as a first part of Comm-B data selector (BDS) code.

BDS2 A value of 0 shall be inserted in this 4-bit (37-40) subfield as a second part of Comm-B data selector (BDS) code.

SCS This 1-bit (66) squitter capability subfield shall report the capability of the transponder to transmit extended squitter position reports. It shall be set to 1 if BDS registers 05 and 06 {HEX} have been updated within the last ten plus or minus one seconds. Otherwise, it shall be set to 0.

SIC This 1-bit (67) surveillance identifier capability subfield shall report the capability of the transponder to support the surveillance identifier (SI) codes.

804.3.1.2.6.10.2.2.2 Updating of the data link capability report. The transponder shall, at intervals not exceeding four seconds, compare the current data link capability status with that last reported and shall, if a difference is noted, initiate a revised data link capability report by Comm-B broadcast (804.3.1.2.6.11.4) for BDS1= 1 (33-36) and BDS 2 = 0 (37-40). The transponder shall initiate, generate and transmit the revised capability report even if the aircraft data link capability is degraded or lost. The transponder shall set the BDS code for the data link capability report.

#### 804.3.1.2.6.10.3 Validation of declared

804.3.1.2.6.10.3.1 On the ground status. Aircraft with an automatic means for determining the on- the – ground condition that are equipped to format extended squitter messages shall perform the following validation check:

If the automatically determined air/ ground status is not available or is “airborne”, no validation shall be performed . if the automatically determined air/ground status is available and “on – the –

ground “ condition is being reported, the air/ground status shall be overridden and changed to “airborne” if the condition given for the vehicle category in table 3-6 are satisfied.

#### 804.3.1.2.6.11 STANDARD LENGTH COMMUNICATIONS PROTOCOLS

804.3.1.2.6.11.1 Comm-A. The interrogator shall deliver a Comm-A message in the MA field of an interrogation UF = 20 or 21.

804.3.1.2.6.11.1.1 Comm-A technical acknowledgement. Acceptance of a Comm-A interrogation shall be automatically technically acknowledged by the transponder, by the transmission of the requested reply (804.3.1.2.10.5.2.2.1).

804.3.1.2.6.11.1.2 Comm-A broadcast. If a Comm-A broadcast interrogation is accepted (804.3.1.2.4.1.2.3.1.3) information transfer shall be handled according to 3.1.2.10.5.2.1.1 but other transponder functions shall not be affected and a reply shall not be transmitted.

#### 804.3.1.2.6.11.2 Ground-initiated Comm-B

804.3.1.2.6.11.2.1 Comm-B data selector, BDS. The 8-bit BDS code shall determine the register whose contents shall be transferred in the MB field of the Comm-B reply. It shall be expressed in two groups of 4 bits each, BDS1 (most significant 4 bits) and BDS2 (least significant 4 bits).

804.3.1.2.6.11.2.2 BDS1 code. The BDS1 code shall be as defined in the RR field of a surveillance or Comm-A interrogation.

804.3.1.2.6.11.2.3 BDS2 code. The BDS2 code shall be as defined in the RRS subfield of the SD field (804.3.1.2.6.1.4.1) when DI = 7. If no BDS2 code is specified (i.e. DI is not equal to 7) it shall signify that BDS2 = 0.

804.3.1.2.6.11.2.4 Protocol. On receipt of such a request, the MB field of the reply shall contain the contents of the requested ground-initiated Comm-B register.

#### 804.3.1.2.6.11.3 Air-initiated Comm-B

804.3.1.2.6.11.3.1 General protocol. The transponder shall announce the presence of an air-initiated Comm-B message with the insertion of code 1 in the DR field. To extract an air-initiated Comm-B message, the interrogator shall transmit a request for a Comm-B message reply in a subsequent interrogation with RR equal to 16 and, if DI equals 7, RRS must be equal to 0 (804.3.1.2.6.11.3.2.1 and 804.3.1.2.6.11.3.3.1). Receipt of this request code shall cause the transponder to transmit the air-initiated Comm-B message. If a command to transmit an airinitiated Comm-B message is received while no message is waiting to be transmitted, the reply shall contain all ZEROs in the MB field.

The reply that delivers the message shall continue to contain code 1 in the DR field. After a Comm-B closeout has been accomplished, the message shall be cancelled and the DR code belonging to this message immediately removed. If another air-initiated Comm-B message is waiting to be transmitted, the transponder shall set the DR code to 1, so that the reply contains the announcement of this next message.

804.3.1.2.6.11.3.2 Additional protocol for multisite air-initiated Comm-B

An interrogator should not attempt to extract a message if it has determined that it is not the reserved site.

804.3.1.2.6.11.3.2.1 Message transfer. An interrogator shall request a Comm-B reservation and extract an airinitiated Comm-B message by transmitting a surveillance or Comm-A interrogation UF equals 4, 5, 20 or 21 containing:

RR = 16

DI = 1

IIS = assigned interrogator identifier

MBS = 1 (Comm-B reservation request)

804.3.1.2.6.11.3.2.1.1 Protocol procedure in response to this interrogation shall depend upon the state of the B-timer which indicates if a Comm-B reservation is active. This timer shall run for TR seconds.

- a) If the B-timer is not running, the transponder shall grant a reservation to the requesting interrogator by:
- 1) storing the IIS of the interrogation as the Comm-B II; and
  - 2) starting the B-timer.

A multisite Comm-B reservation shall not be granted by the transponder unless an air-initiated Comm-B message is waiting to be transmitted and the requesting interrogation contains RR equals 16, DI equals 1, MBS equals 1 and IIS is not 0.

- b) If the B-timer is running and the IIS of the interrogation equals the Comm-B II, the transponder shall restart the B-timer.
- c) If the B-timer is running and the IIS of the interrogation does not equal the Comm-B II, then there shall be no change to the Comm-B II or the B-timer.

804.3.1.2.6.11.3.2.1.2 In each case the transponder shall reply with the Comm-B message in the MB field.

804.3.1.2.6.11.3.2.1.3 An interrogator shall determine if it is the reserved site for this message through coding in the UM field. If it is the reserved site it shall attempt to close out the message in a subsequent interrogation. If it is not the reserved site it shall not attempt to close out the message.

804.3.1.2.6.11.3.2.2 Multisite-directed Comm-B transmissions. To direct an air-initiated Comm-B message to a specific interrogator, the multisite Comm-B protocol shall be used. When the B-timer is not running, the interrogator identifier of the desired destination shall be stored as the Comm-B II. Simultaneously the B-timer shall be started and the DR code shall be set to 1. For a multisite-directed Comm-B message, the B-timer shall not automatically time out but shall continue to run until:

- a) The message is read and closed out by the reserved site; or
- b) The message is cancelled (3.1.2.10.5.4) by the data link avionics.

804.3.1.2.6.11.3.2.3 Multisite Comm-B closeout. The interrogator shall close out a multisite air-initiated Comm-B by transmitting either a surveillance or a Comm-A interrogation containing:

Either DI = 1

IIS = assigned interrogator identifier

MBS = 2 (Comm-B closeout)

Or DI = 0, 1 or 7

IIS = assigned interrogator identifier

PC = 4 (Comm-B closeout)

The transponder shall compare the IIS of the interrogation to the Comm-B II and if the interrogator identifiers do not match, the message shall not be cleared and the status of the Comm-B II, B-timer, and DR code shall not be changed. If the interrogator identifiers match, the transponder shall set the Comm-B II to 0, reset the B-timer, clear the DR code for this message and clear the message itself. The transponder shall not close out a multisite air-initiated Comm-B message unless it has been read out at least once by the reserved site.

804.3.1.2.6.11.3.2.4 Automatic expiration of Comm-B reservation. If the B-timer period expires before a multisite closeout has been accomplished, the Comm-B II shall be set to 0 and the B-timer reset. The Comm-B message and the DR field shall not be cleared by the transponder.

804.3.1.2.6.11.3.3 Additional protocol for non-selective air-initiated Comm-B

804.3.1.2.6.11.3.3.1 Message transfer. The interrogator shall extract the message by transmitting either RR equals 16 and DI is not equal to 7, or RR equals 16, DI equals 7 and RRS equals 0 in a surveillance or Comm-A interrogation.

804.3.1.2.6.11.3.3.2 Comm-B closeout. The interrogator shall close out a non-selective air-initiated Comm-B message by transmitting PC equals 4 (Comm-B closeout). On receipt of this command, the transponder shall perform closeout, unless the B-timer is running. If the B-timer is running, indicating that a multisite reservation is in effect, closeout shall be accomplished as per 804.3.1.2.6.11.3.2.3. The transponder shall not close out a nonselective air-initiated Comm-B message unless it has been read out at least once by an interrogation using nonselective protocols.

804.3.1.2.6.11.3.4 Enhanced air-initiated Comm-B protocol

804.3.1.2.6.11.3.4.1 The transponder shall be capable of storing each of the sixteen II codes: (1) an air-initiated or multisite-directed Comm-B message and (2) the contents of GICB registers 2 through 4.

804.3.1.2.6.11.3.4.2 Enhanced multisite air-initiated Comm-B protocol

804.3.1.2.6.11.3.4.2.1 Initiation. An air-initiated Comm-B message input into the transponder shall be stored in the registers assigned to II = 0.

804.3.1.2.6.11.3.4.2.2 Announcement and extraction. A waiting air-initiated Comm-B message shall be announced in the DR field of the replies to all interrogators for which a multisite directed Comm-B message is not waiting. The UM field of the announcement reply shall indicate that the message is not reserved for any II code, i.e., the IIS subfield shall be set to 0. When a command to read this message is received from a given interrogator, the reply containing the message shall contain an IIS subfield content indicating that the message is reserved for the II code contained in the interrogation from that interrogator. After readout and until closeout, the message shall continue to be assigned to that II code. Once a message is assigned to a specific II code, announcement of this message shall be no longer made in the replies to interrogators with other II codes. If the message is not closed out by the assigned interrogator for the period of the B-timer, the message shall revert back to multisite air-initiated status and the process shall repeat. Only one multisite air-initiated Comm-B message shall be in process at a time.

804.3.1.2.6.11.3.4.2.3 Closeout. A closeout for a multisite air-initiated message shall only be accepted from the interrogator that is currently assigned to transfer the message.

804.3.1.2.6.11.3.4.2.4 Announcement of the next message waiting. The DR field shall indicate a message waiting in the reply to an interrogation containing a Comm-B closeout if an unassigned air-initiated message is



waiting and has not been assigned to a II code, or if a multisite-directed message is waiting for that II code (804.3.1.2.6.11.3.4.3).

#### 804.3.1.2.6.11.3.4.3 Enhanced multisite directed Comm-B protocol

804.3.1.2.6.11.3.4.3.1 Initiation. When a multisite directed message is input into the transponder, it shall be placed in the Comm-B registers assigned to the II code specified for the message. If the registers for this II code are already occupied, (i.e., a multisite directed message is already in process to this II code) the new message shall be queued until the current transaction with that II code is closed out.

804.3.1.2.6.11.3.4.3.2 Announcement. Announcement of a Comm-B message waiting transfer shall be made using the DR field as specified in 804.3.1.2.6.5.2 with the destination interrogator II code contained in the IIS subfield as specified in 804.3.1.2.6.5.3.2. The DR field and IIS subfield contents shall be set specifically for the interrogator that is to receive the reply. A waiting multisite directed message shall only be announced in the replies to the intended interrogator. It shall not be announced in the replies to other interrogators.

804.3.1.2.6.11.3.4.3.3 Closeout. Closeout shall be accomplished as specified in 804.3.1.2.6.11.3.2.3.

804.3.1.2.6.11.3.4.3.4 Announcement of the next message waiting. The DR field shall indicate a message waiting in the reply to an interrogation containing a Comm-B closeout if another multisite directed message is waiting for that II code, or if an air-initiated message is waiting and has not been assigned to a II code. (See 804.3.1.2.6.11.3.4.2.4.)

804.3.1.2.6.11.3.4.4 Enhanced non-selective Comm-B protocol. The availability of a non selective Comm-B message shall be announced to all interrogators. Otherwise, the protocol shall be as specified in 804.3.1.2.6.11.3.3.

#### 804.3.1.2.6.11.4 Comm-B broadcast

804.3.1.2.6.11.4.1 Initiation. A Comm-B broadcast cycle shall not be initiated when an air-initiated Comm-B is waiting to be transmitted. A Comm-B broadcast cycle shall begin with:

- a) the insertion of DR code 4 or 5, (804.3.1.2.6.5.2) into replies with DF 4, 5, 20 or 21; and
- b) the starting of the B-timer.

804.3.1.2.6.11.4.2 Extraction. To extract the broadcast message, an interrogator shall transmit RR equals 16 and DI not equal to 7 or RR equals 16 and DI equals 7 with RRS equals 0 in a subsequent interrogation.

804.3.1.2.6.11.4.3 Expiration. When the B-timer period expires, the transponder shall clear the DR code for this message, discard the present broadcast message and change the broadcast message number (from 1 to 2 or 2 to 1) in preparation for a subsequent Comm-B broadcast.

804.3.1.2.6.11.4.4 Interruption. In order to prevent a Comm-B broadcast cycle from delaying the delivery of an air-initiated Comm-B message, provision shall be made for an air-initiated Comm-B to interrupt a Comm-B broadcast cycle. If a broadcast cycle is interrupted, the B-timer shall be reset, the interrupted broadcast message shall be retained and the message number shall not be changed. Delivery of the interrupted broadcast message shall recommence when no air-initiated Comm-B transaction is in effect. The message shall then be broadcast for the full duration of the B-timer.

804.3.1.2.6.11.4.5 Enhanced broadcast Comm-B protocol. A broadcast Comm-B message shall be announced to all interrogators using II codes. The message shall remain active for the period of the B-timer for each II code. The provision for interruption of a broadcast by non-broadcast Comm-B as specified in 804.3.1.2.6.11.4.4 shall apply separately to each II code. When the B-timer period has been achieved for all II codes, the broadcast message shall be automatically cleared as specified in 804.3.1.2.6.11.4.3. A new broadcast message shall not be initiated until the current broadcast has been cleared.

804.3.1.2.6.11.4.6 The data formats for broadcast comm.-B shall be as specified in Appendix 1 to chapter 5, in Annex 10, volume III, part I.

804.3.1.2.7 EXTENDED LENGTH COMMUNICATION TRANSACTIONS

804.3.1.2.7.1 COMM-C, UPLINK FORMAT 24

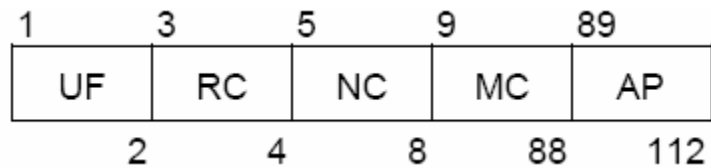

The format of this interrogation shall consist of these fields:

Field	Reference
UF uplink format	804.3.1.2.3.2.1.1
RC reply control	804.3.1.2.7.1.1
NC number of C-segment	804.3.1.2.7.1.2
MC message, Comm-C	804.3.1.2.7.1.3
AP address/parity	804.3.1.2.3.2.1.3

804.3.1.2.7.1.1 RC: Reply control. This 2-bit (3-4) uplink field shall designate segment significance and reply decision.

Coding

- RC
- = 0 signifies uplink ELM initial segment in MC
  - = 1 signifies uplink ELM intermediate segment in MC
  - = 2 signifies uplink ELM final segment in MC
  - = 3 signifies a request for downlink ELM delivery (804.3.1.2.7.7.2)

804.3.1.2.7.1.2 NC: Number of C-segment. This 4-bit (5-8) uplink field shall designate the number of the message segment contained in MC (3.1.2.7.4.2.1). NC shall be coded as a binary number.

804.3.1.2.7.1.3 MC: Message, Comm-C. This 80-bit (9-88) uplink field shall contain:

- a) One of the segments of a sequence used to transmit an uplink ELM to the transponder containing the 4-bit (9-12) IIS subfield; or
- b) control codes for a downlink ELM, the 16-bit (9-24) SRS subfield (804.3.1.2.7.7.2.1) and the 4-bit (25-28) IIS subfield.

804.3.1.2.7.2 INTERROGATION-REPLY PROTOCOL FOR UF24

Note— Interrogation-reply co-ordination for the above format follows the protocol outlined in Table 3-5 (804.3.1.2.4.1.3.2.2).

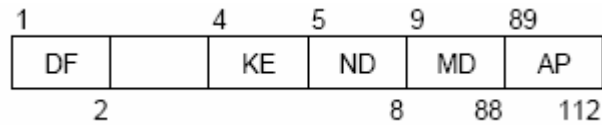

The format of this reply shall consist of these fields:

Field	Reference
DF downlink format	804.3.1.2.3.2.1.2
Spare — 1 bit	
KE control, ELM	804.3.1.2.7.3.1
ND number of D-segment	804.3.1.2.7.3.2
MD message, Comm-D	804.3.1.2.7.3.3
AP address/parity	804.3.1.2.3.2.1.3

804.3.1.2.7.3.1 KE: Control, ELM. This 1-bit (4) downlink field shall define the content of the ND and MD fields.

**Coding**

KE = 0 signifies downlink ELM transmission  
 1 signifies uplink ELM acknowledgement

804.3.1.2.7.3.2 ND: Number of D-segment. This 4-bit (5-8) downlink field shall designate the number of the message segment contained in MD (3.1.2.7.2). ND shall be coded as a binary number.

804.3.1.2.7.3.3 MD: Message, Comm-D. This 80-bit (9-88) downlink field shall contain:

- a) One of the segments of a sequence used to transmit a downlink ELM to the interrogator; or
- b) Control codes for an uplink ELM.

804.3.1.2.7.4 MULTISITE UPLINK ELM PROTOCOL

804.3.1.2.7.4.1 Multisite uplink ELM reservation. An interrogator shall request a reservation for an uplink ELM by transmitting a surveillance or Comm-A interrogation containing:

DI = 1  
 IIS = assigned interrogator identifier  
 MES = 1 or 5 (uplink ELM reservation request)

804.3.1.2.7.4.1.1 Protocol procedure in response to this interrogation shall depend upon the state of the C-timer which indicates if an uplink ELM reservation is active. This timer shall run for TR seconds.

- a) If the C-timer is not running the transponder shall grant a reservation to the requesting interrogator by:
  - 1) Storing the IIS of the interrogation as the Comm-C II and,
  - 2) Starting the C-timer.

- b) If the C-timer is running and the IIS of the interrogation equals the Comm-C II, the transponder shall restart the C-timer.
- c) If the C-timer is running and the IIS of the interrogation does not equal the Comm-C II, there shall be no change to the Comm-C II or the C-timer.

804.3.1.2.7.4.1.2 An interrogator shall not start ELM activity unless, during the same scan, having requested an uplink ELM status report, it has received its own interrogator identifier as the reserved interrogator for uplink ELM in the UM field.

804.3.1.2.7.4.1.3 If uplink ELM delivery is not completed on the current scan, the interrogator shall ensure that it still has a reservation before delivering additional segments on a subsequent scan.

804.3.1.2.7.4.2 Multisite uplink ELM delivery. The minimum length of an uplink ELM shall be 2 segments, the maximum length shall be 16 segments.

804.3.1.2.7.4.2.1 Initial segment transfer. The interrogator shall begin the ELM uplink delivery for an n-segment message (NC values from 0 to n-1) by a Comm-C transmission containing RC equals 0. The message segment transmitted in the MC field shall be the last segment of the message and shall carry NC equals n-1.

On receipt of an initializing segment (RC = 0) the transponder shall establish a “setup” defined as:

- a) Clearing the number and content of previous segment storage registers and the associated TAS field;
- b) Assigning storage space for the number of segments announced in NC of this interrogation; and
- c) Storing the MC field of the segment received.

The transponder shall not reply to this interrogation.

Receipt of another initializing segment shall result in a new setup within the transponder.

804.3.1.2.7.4.2.2 Transmission acknowledgement. The transponder shall use the TAS subfield to report the segments received so far in an uplink ELM sequence. The information contained in the TAS subfield shall be continually updated by the transponder as segments are received.

804.3.1.2.7.4.2.2.1 TAS, transmission acknowledgement subfield in MD. This 16-bit (17-32) downlink subfield in MD reports the segment numbers received so far in an uplink ELM sequence. Starting with bit 17, which denotes segment number 0, each of the following bits shall be set to ONE if the corresponding segment of the sequence has been received. TAS shall appear in MD if KE equals 1 in the same reply.

804.3.1.2.7.4.2.3 Intermediate segment transfer. The interrogator shall transfer intermediate segments by transmitting Comm-C interrogations with RC equals 1. The transponder shall store the segments and update TAS only if the setup of 804.3.1.2.7.4.2.1 is in effect and if the received NC is smaller than the value stored at receipt of the initial segment. No reply shall be generated on receipt of an intermediate segment.

804.3.1.2.7.4.2.4 Final segment transfer. The interrogator shall transfer a final segment by transmitting a Comm-C interrogation with RC equals 2. This interrogation may contain any message segment. The

transponder shall store the content of the MC field and update TAS if the setup of 804.3.1.2.7.4.2.1 is in effect and if the received NC is smaller than the value of the initial segment NC. The transponder shall reply under all circumstances as per 804.3.1.2.7.4.2.5.

804.3.1.2.7.4.2.5 Acknowledgement reply. On receipt of a final segment, the transponder shall transmit a Comm-D reply (DF = 24), with KE equals 1 and with the TAS subfield in the MD field. This reply shall be transmitted at 128 microseconds plus or minus 0.25 microsecond following the sync phase reversal of the interrogation delivering the final segment.

804.3.1.2.7.4.2.6 Completed message. The transponder shall deem the message complete if all segments announced by NC in the initializing segment have been received. If the message is complete, the message content shall be delivered to the outside via the ELM interface of 804.3.1.2.10.5.2.1.3 and cleared. No later-arriving segments shall be stored. The TAS content shall remain unchanged until either a new setup is called for (804.3.1.2.7.4.2.1) or until closeout (804.3.1.2.7.4.2.8).

804.3.1.2.7.4.2.7 C-timer restart. The C-timer shall be restarted each time that a received segment is stored and the Comm-C II is not 0.

804.3.1.2.7.4.2.8 Multisite uplink ELM closeout. The interrogator shall close out a multisite uplink ELM by transmitting either a surveillance or a Comm-A interrogation containing:

Either DI = 1  
IIS = assigned interrogator identifier  
MES = 2, 6 or 7 (uplink ELM closeout)

Or DI = 0, 1 or 7  
IIS = assigned interrogator identifier  
PC = 5 (uplink ELM closeout)

The transponder shall compare the IIS of the interrogation to the Comm-C II and if the interrogator identifiers do not match, the state of the ELM uplink process shall not be changed.

If the interrogator identifiers match, the transponder shall set the Comm-C II to 0, reset the C-timer, clear the stored TAS and discard any stored segments of an incomplete message.

804.3.1.2.7.4.2.9 Automatic multisite uplink ELM closeout. If the C-timer period expires before a multisite closeout has been accomplished the closeout actions described in 3.1.2.7.4.2.8 shall be initiated automatically by the transponder.

#### 804.3.1.2.7.5 NON-SELECTIVE UPLINK ELM

Non-selective uplink ELM delivery shall take place as for multisite uplink ELMs described in 804.3.1.2.7.4.2. The interrogator shall close out an uplink ELM by transmitting PC equals 5 (uplink ELM closeout) in a surveillance or Comm-A interrogation. On receipt of this command, the transponder shall perform closeout, unless the Ctimer is running. If the C-timer is running, indicating that a multisite reservation is in effect, the closeout shall be accomplished as per 804.3.1.2.7.4.2.8. An uncompleted message, present when the closeout is accepted, shall be cancelled.

#### 804.3.1.2.7.6 ENHANCED UPLINK ELM PROTOCOL

##### 804.3.1.2.7.6.1 General

804.3.1.2.7.6.1.1 The interrogator shall determine from the data link capability report whether the transponder supports the enhanced protocols. If the enhanced protocols are supported, uplink ELMs delivered using the multisite protocol may be delivered without a prior reservation. If the enhanced protocols are not supported by both the interrogator and the transponder, the multisite reservation protocols specified in 804.3.1.2.7.4.1 shall be used.

804.3.1.2.7.6.1.2 If the transponder and the interrogator are equipped for the enhanced protocol, the interrogator should use the enhanced uplink protocol.

804.3.1.2.7.6.1.3 The transponder shall be capable of storing a sixteen segment message for each of the sixteen II codes.

804.3.1.2.7.6.2 Reservation processing. The transponder shall support reservation processing for each II code as specified in 804.3.1.2.7.4.1

804.3.1.2.7.6.3 Enhanced uplink ELM delivery and closeout. The transponder shall process received segments separately by II code. For each value of II code, uplink ELM delivery and closeout shall be performed as specified in 804.3.1.2.7.4.2 except that the MD field used to transmit the technical acknowledgment shall also contain the 4-bit (33-36) IIS subfield.

#### 804.3.1.2.7.7 MULTISITE DOWNLINK ELM PROTOCOL

804.3.1.2.7.7.1 Initialization. The transponder shall announce the presence of a downlink ELM of n segments by making the binary code corresponding to the decimal value  $15 + n$  available for insertion in the DR field of a surveillance or Comm-B reply, DF equals 4, 5, 20, 21. This announcement shall remain active until the ELM is closed out (804.3.1.2.7.7.3, 804.3.1.2.7.8.1).

804.3.1.2.7.7.1.1 Multisite downlink ELM reservation. An interrogator shall request a reservation for extraction of a downlink ELM by transmitting a surveillance or Comm-A interrogation containing:

DI = 1

IIS = assigned interrogator identifier

MES = 3 or 6 (downlink ELM reservation request)

804.3.1.2.7.7.1.1.1 Protocol procedure in response to this interrogation shall depend upon the state of the Dtimer which indicates if a downlink ELM reservation is active. This timer shall run for TR seconds.

a) If the D-timer is not running, the transponder shall grant a reservation to the requesting interrogator by:

1) Storing the IIS of the interrogation as the Comm-D II; and

2) Starting the D-timer.

A multisite downlink ELM reservation shall not be granted by the transponder unless a downlink ELM is waiting to be transmitted.

b) If the D-timer is running and the IIS of the interrogation equals the Comm-D II, the transponder shall restart the D-timer; and

c) If the D-timer is running and the IIS of the interrogation does not equal the Comm-D II, there shall be no change to the Comm-D II or D-timer.

804.3.1.2.7.7.1.1.2 An interrogator shall determine if it is the reserved site through coding in the UM field and, if so, it may proceed to request delivery of the downlink ELM. Otherwise, ELM activity shall not be started during this scan and a new reservation request may be made during the next scan.

804.3.1.2.7.7.1.1.3 If downlink ELM activity is not completed on the current scan, the interrogator shall ensure that it still has a reservation before requesting additional segments on a subsequent scan.

804.3.1.2.7.7.1.1.4 Multisite-directed downlink ELM transmissions. To direct a downlink ELM message to a specific interrogator, the multisite downlink ELM protocol shall be used. When the D-timer is not running, the interrogator identifier of the desired destination shall be stored as the Comm-D II. Simultaneously, the D-timer shall be started and the DR code (804.3.1.2.7.7.1) shall be set. For a multisite-directed downlink ELM, the D-timer shall not automatically time out but shall continue to run until:

- a) The message is read and closed out by the reserved site; or
- b) The message is cancelled (804.3.1.2.10.5.4) by the data link avionics.

804.3.1.2.7.7.2 Delivery of downlink ELMs. The interrogator shall extract a downlink ELM by transmitting a Comm-C interrogation with RC equals 3. This interrogation shall carry the SRS subfield which specifies the segments to be transmitted. On receipt of this request, the transponder shall transfer the requested segments by means of Comm-D replies with KE equals 0 and ND corresponding to the number of the segment in MD. The first segment shall be transmitted 128 microseconds plus or minus 0.25 microsecond following the sync phase reversal of the interrogation requesting delivery and subsequent segments shall be transmitted at a rate of one every 136 microseconds plus or minus 1 microsecond. If a request is received to transmit downlink ELM segments and no message is waiting, each reply segment shall contain all ZEROs in the MD field.

804.3.1.2.7.7.2.1 SRS, segment request subfield in MC. This 16-bit (9-24) uplink subfield in MC shall request the transponder to transfer downlink ELM segments. Starting with bit 9, which denotes segment number 0, each of the following bits shall be set to ONE if the transmission of the corresponding segment is requested. SRS shall appear in MC if RC equals 3 in the same interrogation.

804.3.1.2.7.7.2.2 D-timer restart. The D-timer shall be restarted each time that a request for Comm-D segments is received if the Comm-D II is non-zero.

804.3.1.2.7.7.3 Multisite downlink ELM closeout. The interrogator shall close out a multisite downlink ELM by transmitting either a surveillance or a Comm-A interrogation containing:

Either DI = 1  
IIS = assigned interrogator identifier  
MES = 4, 5 or 7 (downlink ELM closeout)

Or DI = 0, 1 or 7  
IIS = assigned interrogator identifier  
PC = 6 (downlink ELM closeout).

The transponder shall compare the IIS of the interrogation to the Comm-D II and if the interrogator identifiers do not match, the state of the downlink process shall not be changed.

If the interrogator identifiers match, and if a request for transmission has been complied with at least once, the transponder shall set the Comm-D II to 0, reset the D-timer, clear the DR code for this message and clear the message itself.

If another downlink ELM is waiting to be transmitted, the transponder shall set the DR code (if no Comm-B message is waiting to be delivered) so that the reply contains the announcement of the next message.

804.3.1.2.7.7.4 Automatic expiration of downlink ELM reservation. If the D-timer period expires before a multisite closeout has been accomplished, the Comm-D II shall be set to 0, and the D-timer reset. The message and DR code shall not be cleared.

#### 804.3.1.2.7.8 NON-SELECTIVE DOWNLINK ELM

Non-selective downlink ELM delivery shall take place as described in 804.3.1.2.7.7.2.

804.3.1.2.7.8.1 Non-selective downlink ELM closeout. The interrogator shall close out a non-selective downlink ELM by transmitting PC equals 6 (downlink ELM closeout) in a surveillance or Comm-A interrogation. On receipt of this command, and if a request for transmission has been complied with at least once, the transponder shall perform closeout unless the D-timer is running. If the D-timer is running, indicating that a multisite reservation is in effect, the closeout shall be accomplished as per 804.3.1.2.7.7.3.

#### 804.3.1.2.7.9 ENHANCED DOWNLINK ELM PROTOCOL

##### 804.3.1.2.7.9.1 General

804.3.1.2.7.9.1.1 The interrogator shall determine from the data link capability report whether the transponder supports the enhanced protocols. If the enhanced protocols are supported, downlink ELMs delivered using the multisite-directed protocol may be delivered without a prior reservation. If the enhanced protocols are not supported by both the interrogator and the transponder, the multisite reservation protocols specified in 804.3.1.2.6.1.1 shall be used for multisite and multisite-directed downlink ELMs.

804.3.1.2.7.9.1.2 If the transponder and the interrogator are equipped for the enhanced protocol, the interrogator should use the enhanced downlink protocol.

##### 804.3.1.2.7.9.2 Enhanced multisite downlink ELM protocol

804.3.1.2.7.9.2.1 The transponder shall be capable of storing a sixteen segment message for each of the sixteen II codes.

804.3.1.2.7.9.2.2 Initialization. A multisite message input into the transponder shall be stored in the registers assigned to II = 0.

804.3.1.2.7.9.2.3 Announcement and extraction. A waiting multisite downlink ELM message shall be announced in the DR field of the replies to all interrogators for which a multisite directed downlink ELM message is not waiting. The UM field of the announcement reply shall indicate that the message is not reserved for any II code, i.e. the IIS subfield shall be set to 0. When a command to reserve this message is received from a given interrogator, the message shall be reserved for the II code contained in the interrogation from that interrogator. After readout and until closeout, the message shall continue to be assigned to that II code. Once a message is assigned to a specific II code, announcement of this message shall no longer be made in the replies to interrogators with other II codes. If the message is not closed out by the associated interrogator for the period of the D-timer, the message shall revert back to



multisite status and the process shall repeat. Only one multisite downlink ELM message shall be in process at a time.

804.3.1.2.7.9.2.4 Closeout. A closeout for a multisite message shall only be accepted from the interrogator that was assigned most recently to transfer the message.

804.3.1.2.7.9.2.5 Announcement of the next message waiting. The DR field shall indicate a message waiting in the reply to an interrogation containing a downlink ELM closeout if an unassigned multisite downlink ELM is waiting, or if a multisite directed message is waiting for that II code (804.3.1.2.7.9.2).

804.3.1.2.7.9.3 Enhanced multisite directed downlink ELM protocol

804.3.1.2.7.9.3.1 Initialization. When a multisite directed message is input into the transponder, it shall be placed in the downlink ELM registers assigned to the II code specified for the message. If the registers for this II code are already in use (i.e. a multisite directed downlink ELM message is already in process for this II code), the new message shall be queued until the current transaction with that II code is closed out.

804.3.1.2.7.9.3.2 Announcement. Announcement of a downlink ELM message waiting transfer shall be made using the DR field as specified in 804.3.1.2.7.7.1 with the destination interrogator II code contained in the IIS subfield as specified in 804.3.1.2.6.5.3.2. The DR field and IIS subfield contents shall be set specifically for the interrogator that is to receive the reply. A waiting multisite directed message shall only be announced in the replies to the intended interrogator. It shall not be announced in replies to other interrogators.

804.3.1.2.7.9.3.3 Delivery. An interrogator shall determine if it is the reserved site through coding in the UM field and, if so, it may proceed to request delivery of the downlink ELM. The delivery shall be performed as specified in 804.3.1.2.7.7.2. The transponder shall transmit the message contained in the buffer associated with the II code specified in the IIS subfield of the segment request interrogation.

804.3.1.2.7.9.3.4 Closeout. Closeout shall be accomplished as specified in 804.3.1.2.7.7.3 except that a message closeout shall only be accepted from the interrogator with a II code equal to the one that transferred the message.

804.3.1.2.7.9.3.5 Announcement of the next message waiting. The DR field shall indicate a message waiting in the reply to an interrogation containing a downlink ELM closeout if another multisite directed message is waiting for that II code, or if a downlink message is waiting that has not been assigned a II code (804.3.1.2.7.9.2).

804.3.1.2.7.9.4 Enhanced non-selective downlink ELM protocol. The availability of a non-selective downlink ELM message shall be announced to all interrogators. Otherwise, the protocol shall be as specified in 804.3.1.2.7.7.

804.3.1.2.8 AIR-AIR SERVICE AND SQUITTER TRANSACTIONS

804.3.1.2.8.1 SHORT AIR-AIR SURVEILLANCE, UPLINK FORMAT 0

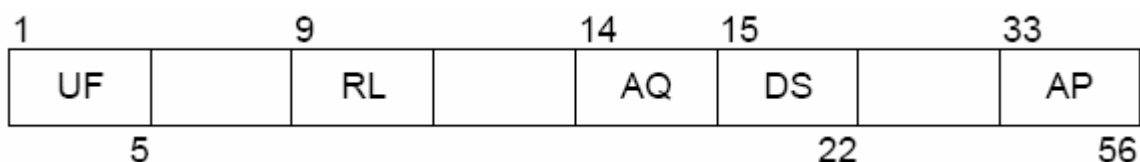

The format of this interrogation shall consist of these fields:

Field	Reference
UF uplink format	804.3.1.2.3.2.1.1
Spare — 3 bits	
RL reply length	804.3.1.2.8.1.2
Spare — 4 bits	
AQ acquisition	804.3.1.2.8.1.1
DS data selector	804.3.1.2.8.1.3
Spare — 10 bits	
AP address/parity	804.3.1.2.3.2.1.3

804.3.1.2.8.1.1 AQ: Acquisition. This 1-bit (14) uplink field shall contain a code which controls the content of the RI field.

804.3.1.2.8.1.2 RL: Reply length. This 1-bit (9) uplink field shall command the format to be used for the reply.

**Coding**

0 signifies a reply with DF = 0

1 signifies no reply

804.3.1.2.8.1.3 DS: Data selector. This 8-bit (15-22) uplink field shall contain the BDS code (804.3.1.2.6.11.2.1) of the GICB register whose contents shall be returned to the corresponding reply with DF equals 16.

804.3.1.2.8.2 SHORT AIR-AIR SURVEILLANCE, DOWNLINK FORMAT 0

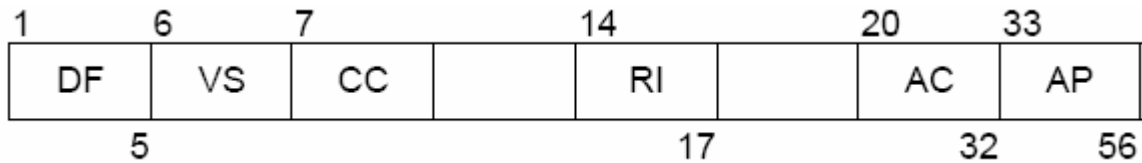

This reply shall be sent in response to an interrogation with UF equals 0 and RL equals 0. The format of this reply shall consist of these fields:

Field	Reference
DF downlink format	804.3.1.2.3.2.1.2
VS vertical status	804.3.1.2.8.2.1
CC cross-link capability	804.3.1.2.8.2.3
Spare — 6 bits	
RI reply information	804.3.1.2.8.2.2
Spare — 2 bits	
AC altitude code	804.3.1.2.6.5.4
AP address/parity	804.3.1.2.3.2.1.3

804.3.1.2.8.2.1 VS: Vertical status: This 1-bit (6) downlink field shall indicate the status of the aircraft (804.3.1.2.6.10.1.2).

**Coding**

0 signifies that the aircraft is airborne

1 signifies that the aircraft is on the ground

804.3.1.2.8.2.2 RI: Reply information, air-air. This 4-bit (14-17) downlink field shall report the aircraft's maximum cruising true airspeed capability and type of reply to interrogating aircraft. The coding shall be as follows:

- 0 signifies a reply to an air-air interrogation UF = 0 with AQ = 0, no operating ACAS
- 1-7 reserved for ACAS
- 8-15 signifies a reply to an air-air interrogation UF = 0 with AQ = 1 and that the maximum

Airspeed is as follows:

- 8 no maximum airspeed data available
- 9 maximum airspeed is .LE. 140 km/h (75 kt)
- 10 maximum airspeed is .GT. 140 and .LE. 280 km/h (75 and 150 kt)
- 11 maximum airspeed is .GT. 280 and .LE. 560 km/h (150 and 300 kt)
- 12 maximum airspeed is .GT. 560 and .LE. 1 110 km/h (300 and 600 kt)
- 13 maximum airspeed is .GT. 1 110 and .LE. 2 220 km/h (600 and 1 200 kt)
- 14 maximum airspeed is more than 2 220 km/h (1 200 kt)
- 15 not assigned.

804.3.1.2.8.2.3 CC: Cross-link capability. This 1-bit (7) downlink field shall indicate the ability of the transponder to support the cross-link capability, i.e. decode the contents of the DS field in an interrogation with UF equals 0 and respond with the contents of the specified GICB register in the corresponding reply with DF equals 16.

Coding

- 0 signifies that the transponder cannot support the cross-link capability
- 1 signifies that the transponder supports the cross-link capability.

804.3.1.2.8.3 LONG AIR-AIR SURVEILLANCE, DOWNLINK FORMAT 16

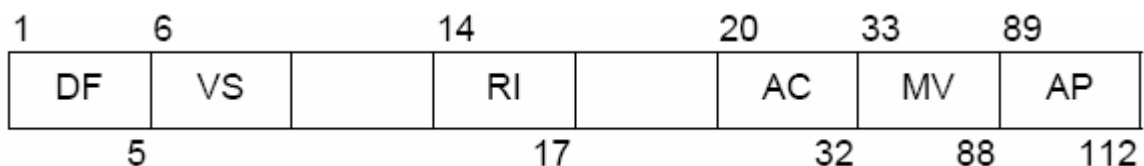

This reply shall be sent in response to an interrogation with UF equals 0 and RL equals 1. The format of this reply shall consist of these fields:

Field	Reference
DF downlink format	804.3.1.2.3.2.1.2
VS vertical status	804.3.1.2.8.2.1
Spare — 7 bits	
RI reply information	804.3.1.2.8.2.2
Spare — 2 bits	
AC altitude code	804.3.1.2.6.5.4
MV message, ACAS	804.3.1.2.8.3.1
AP address/parity	804.3.1.2.3.2.1.3

804.3.1.2.8.3.1 MV: Message, ACAS. This 56-bit (33-88) downlink field shall contain GICB information as requested in the DS field of the UF 0 interrogation that elicited the reply.

804.3.1.2.8.4 AIR-AIR TRANSACTION PROTOCOL

The most significant bit (bit 14) of the RI field of an air-air reply shall replicate the value of the AQ field (bit 14) received in an interrogation with UF equals 0.

If AQ equals 0 in the interrogation, the RI field of the reply shall contain the value 0.

If AQ equals 1 in the interrogation, the RI field of the reply shall contain the maximum cruising true airspeed capability of the aircraft as defined in 804.3.1.2.8.2.2.

In response to a UF = 0 with RL = 1 and DS = 0, the transponder shall reply with a DF = 16 reply in which the MV field shall contain the contents of the GICB register designated by the DS value. In response to a UF = 0 with RL = 1 and DS = 0, the transponder shall reply with a DF = 16 with an MV field of all zeros. Receipt of a UF = 0 with DS = 0 but RL = 0 shall have no associated ACAS cross-link action, and the transponder shall reply as specified in 804.3.1.2.8.2.2.

804.3.1.2.8.5 ACQUISITION SQUITTER

804.3.1.2.8.5.1 Acquisition squitter format. The format used for acquisition squitter transmissions shall be the all-call reply, (DF = 11) with II = 0.

804.3.1.2.8.5.2 Acquisition squitter rate. Acquisition squitter transmissions shall be emitted at random intervals that are uniformly distributed over the range from 0.8 to 1.2 seconds relative to the previous squitter, with the following exceptions:

- a) The scheduled acquisition squitter shall be delayed if the transponder is in a transaction cycle (804.3.1.2.4.1);
- b) The acquisition squitter shall be delayed if an extended squitter is in process;
- c) The scheduled acquisition squitter shall be delayed if a mutual suppression interface is active or
- d) Acquisition squitters shall only be transmitted on the surface if the transponder is not reporting the surface position type of Mode S extended squitter.

An acquisition squitter shall not be interrupted by link transactions or mutual suppression activity after the squitter transmission has begun.

804.3.1.2.8.5.3 Acquisition squitter antenna selection. Transponders operating with antenna diversity (804.3.1.2.10.4) shall transmit acquisition squitters as follows:

- a) When airborne (804.3.1.2.8.6.7), the transponder shall transmit acquisition squitters alternately from the two antennas; and
- b) When on the surface (804.3.1.2.8.6.7), the transponder shall transmit acquisition squitters under control of SAS (804.3.1.2.6.1.4.1 f)).

804.3.1.2.8.6 EXTENDED SQUITTER, DOWNLINK FORMAT 17

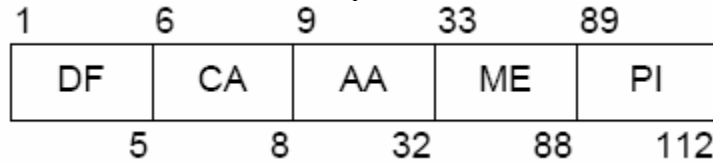

804.3.1.2.8.6.1 Extended squitter format. The format used for the extended squitter shall be a 112-bit downlink format (DF = 17) containing the following fields:

Field	Reference
DF downlink format	804.3.1.2.3.2.1.2
CA capability	804.3.1.2.5.2.2.1
AA address, announced	804.3.1.2.5.2.2.2
ME message, extended squitter	804.3.1.2.8.6.2
PI parity/interrogator identifier	804.3.1.2.3.2.1.4

The PI field shall be encoded with II equal to 0.

804.3.1.2.8.6.2 ME: Message, extended squitter. This 56-bit (33-88) downlink field in DF = 17 shall be used to transmit broadcast messages.

804.3.1.2.8.6.3 Extended squitter types

804.3.1.2.8.6.3.1 Airborne position squitter. The airborne position extended squitter type shall use format DF = 17 with the contents of GICB register 05 {HEX} inserted in the ME field.

804.3.1.2.8.6.3.1.1 SSS, surveillance status subfield in ME. The transponder shall report the surveillance status of the transponder in this 2-bit (38, 39) subfield of ME when ME contains an airborne position squitter report.

**Coding**

- 0 signifies no status information
- 1 signifies transponder reporting permanent alert condition (804.3.1.2.6.10.1.1.1)
- 2 signifies transponder reporting a temporary alert condition (804.3.1.2.6.10.1.1.2)
- 3 signifies transponder reporting SPI condition (804.3.1.2.6.10.1.3)

Codes 1 and 2 shall take precedence over code 3.

804.3.1.2.8.6.3.1.2 ACS, altitude code subfield in ME. Under control of ATS (3.1.2.8.6.3.1.3), the transponder shall report the barometric altitude code in this 12-bit (41-52) subfield of ME when ME contains an airborne position report. The contents of the ACS shall be as specified for the 13-bit AC field (3.1.2.6.5.4) except that the M-bit (bit 26) shall be omitted.

804.3.1.2.8.6.3.1.3 Control of ACS reporting. Transponder reporting of altitude data in ACS shall take place when the 1-bit altitude type subfield (ATS) (3.1.2.8.6.8.2) has the value of 0. Transponder reporting of altitude data in ACS shall be inhibited when ATS has the value 1.

804.3.1.2.8.6.3.2 Surface position squitter. The surface position extended squitter type shall use format DF = 17 with the contents of GICB register 06 {HEX} inserted in the ME field.

- 804.3.1.2.8.6.3.3 Aircraft identification squitter. The aircraft identification extended squitter type shall use format DF = 17 with the contents of GICB register 08 {HEX} inserted in the ME field.
- 804.3.1.2.8.6.3.4 Airborne velocity squitter. The airborne velocity extended squitter type shall use format DF = 17 with the contents of GICB register 09 {HEX} inserted in the ME field.
- 804.3.1.2.8.6.3.5 Event-driven squitter. The event-driven extended squitter type shall use format DF = 17 with the contents of GICB register 0A {HEX} inserted in the ME field.
- 804.3.1.2.8.6.4 Extended squitter rate
- 804.3.1.2.8.6.4.1 Initialization. At power up initialization, the transponder shall commence operation in a mode in which it broadcasts only acquisition squitters (3.1.2.8.5). The transponder shall initiate the broadcast of extended squitters for airborne position, surface position, airborne velocity and aircraft identification when data are inserted into GICB registers 05, 06, 09 and 08 {HEX}, respectively. This determination shall be made individually for each squitter type. When extended squitters are broadcast, transmission rates shall be as indicated in the following paragraphs. Acquisition squitters shall be reported in addition to extended squitters unless the acquisition squitter is inhibited (804.2.1.5.4). Acquisition squitters shall always be reported if extended position or velocity squitters are not reported.
- 804.3.1.2.8.6.4.2 Airborne position squitter rate. Airborne position squitter transmissions shall be emitted when the aircraft is airborne (804.3.1.2.8.6.7) at random intervals that are uniformly distributed over the range from 0.4 to 0.6 seconds relative to the previous airborne position squitter, with the exceptions as specified in 804.3.1.2.8.6.4.7.
- 804.3.1.2.8.6.4.3 Surface position squitter rate. Surface position squitter transmissions shall be emitted when the aircraft is on the surface (804.3.1.2.8.6.7) using one of two rates depending upon whether the high or low squitter rate has been selected (804.3.1.2.8.6.9). When the high squitter rate has been selected, surface position squitters shall be emitted at random intervals that are uniformly distributed over the range from 0.4 to 0.6 seconds relative to the previous surface position squitter (termed the high rate). When the low squitter rate has been selected, surface position squitters shall be emitted at random intervals that are uniformly distributed over the range of 4.8 to 5.2 seconds relative to the previous surface position squitter (termed the low rate). Exceptions to these transmission rates are specified in 804.3.1.2.8.6.4.7.
- 804.3.1.2.8.6.4.4 Aircraft identification squitter rate. Aircraft identification squitter transmissions shall be emitted at random intervals that are uniformly distributed over the range of 4.8 to 5.2 seconds relative to the previous identification squitter when the aircraft is reporting the airborne position squitter type, or when the aircraft is reporting the surface position squitter type and the high surface squitter rate has been selected. When the surface position squitter type is being reported at the low surface rate, the aircraft identification squitter shall be emitted at random intervals that are uniformly distributed over the range of 9.6 to 10.4 seconds relative to the previous identification squitter. Exceptions to these transmission rates are specified in 804.3.1.2.8.6.4.7.
- 804.3.1.2.8.6.4.5 Airborne velocity squitter rate. Airborne velocity squitter transmissions shall be emitted when the aircraft is airborne (804.3.1.2.8.6.7) at random intervals that are uniformly distributed over the range from 0.4 to 0.6 seconds relative to the previous airborne velocity squitter, with the exceptions as specified in 804.3.1.2.8.6.4.7.
- 804.3.1.2.8.6.4.6 Event-driven squitter rate. The event-driven squitter shall be transmitted once, each time that GICB register 0A {HEX} is loaded, while observing the delay conditions specified in 804.3.1.2.8.6.4.7.

The maximum transmission rate for the event-driven squitter shall be limited by the transponder to twice per second. If a message is inserted in the event-driven register and cannot be transmitted due to rate limiting, it shall be held and transmitted when the rate limiting condition has cleared. If a new message is received before transmission is permitted, it shall overwrite the earlier message.

804.3.1.2.8.6.4.7 Delayed transmission. Extended squitter transmission shall be delayed in the following circumstances:

- a) If the transponder is in a transaction cycle (804.3.1.2.4.1);
- b) If an acquisition or another type of extended squitter is in process; or
- c) If a mutual suppression interface is active.

The delayed squitter shall be transmitted as soon as the transponder becomes available.

804.3.1.2.8.6.5 Extended squitter antenna selection. Transponders operating with antenna diversity (804.3.1.2.10.4) shall transmit extended squitters as follows:

- a) When airborne (804.3.1.2.8.6.7), the transponder shall transmit each type of extended squitter alternately from the two antennas; and
- b) When on the surface (804.3.1.2.8.6.7), the transponder shall transmit extended squitters under control of SAS (804.3.1.2.6.1.4.1 f)).

In the absence of any SAS commands, use of the top antenna only shall be the default condition.

804.3.1.2.8.6.6 Register time-out. The transponder shall clear all 56-bits of the airborne position, surface position, squitter status and airborne velocity information GICB registers 05, 06, 07 and 09 {HEX} if these registers are not updated within two seconds of the previous update. This time-out shall be determined separately for each of these registers.

804.3.1.2.8.6.7 Airborne/surface state determination. Aircraft with an automatic means of determining on-the-ground conditions shall use this input to select whether to report the airborne or surface message types. Aircraft without such means shall report the airborne type messages. Aircraft with or without such automatic on-the-ground determination shall use position message types as commanded by control codes in TCS (804.3.1.2.6.1.4.1 f)). After time-out of the TCS commands, control of airborne/surface determination shall revert to the means described above.

804.3.1.2.8.6.8 Squitter status reporting. A GICB request (804.3.1.2.6.11.2) containing RR equals 16 and DI equals 7 and RRS equals 7 shall cause the resulting reply to contain the squitter status report in its MB field.

804.3.1.2.8.6.8.1 TRS, transmission rate subfield in MB. The transponder shall report the capability of the aircraft to automatically determine its surface squitter rate and its current squitter rate in this 2-bit (33, 34) subfield of MB.

Coding

- 0 signifies no capability to automatically determine surface squitter rate
- 1 signifies that the high surface squitter rate has been selected
- 2 signifies that the low surface squitter rate has been selected
- 3 unassigned

804.3.1.2.8.6.8.2 ATS, altitude type subfield in MB. The transponder shall report the type of altitude being provided in the airborne extended squitter in this 1-bit (35) subfield of MB when the reply contains the contents of GICB register 07 {HEX}.

Coding

- 0 signifies that barometric altitude is being reported
- 1 signifies that navigation-derived height is being reported

804.3.1.2.8.6.9 Surface squitter rate control. Surface squitter rate shall be determined as follows:

- a) Once per second the contents of the TRS shall be read. If the value of TRS is 0 or 1, the transponder shall transmit surface squitters at the high rate. If the value of TRS is 2, the transponder shall transmit surface squitters at the low rate;
- b) The squitter rate determined via TRS shall be subject to being overridden by commands received via RCS (804.3.1.2.6.1.4.1 f). RCS code 1 shall cause the transponder to squitter at the high rate for 60 seconds. RCS code 2 shall cause the transponder to squitter at the low rate for 60 seconds. These commands shall be able to be refreshed for a new 60 second period before time-out of the prior period; and
- c) After time-out and in the absence of RCS codes 1 and 2, control shall return to TRS.

804.3.1.2.8.6.10 Latitude /longitude coding using compact position reporting (CPR) mode S extended squitter uses compact position reporting (CPR) to encode latitude and longitude efficiently into messages. The method used to encode /decode CPR shall comply with the equation in Annex 10, volume III, Appendix 1 to chapter 5.

804.3.1.2.8.7 EXTENDED SQUITTER /NON TRANSPONDER (ES/NT) DOWNLINK FORMAT 18

10010	CF:3	AA:24	ME:56	PI:24
-------	------	-------	-------	-------

804.3.1.2.8.7.1 ES/NT format. The format used for ES/NT shall be 112-bit downlink format (DF=18) containing the following fields

Field	reference
DF downlink format	804.3.1.2.3.2.1.2
CF control field	804.3.1.2.8.7.2
AA address, announced	804.3.1.5.2.2.2
ME message /extended squitter	804.3.1.2.8.6.2
PI parity /interrogator identifier	804.3.1.2.3.2.1.4

The PI field shall be encoded with II and SI equal to zero.

804.3.1.2.8.7.2 Control field. This 3-bit (6-8) downlink field is DF= 18 shall be used to define the format of the 112 bit transmission.

- Code 0 = ADS –B
- Code 1-7 = reserved



804.3.1.2.8.7.3 ES/NT squitter types.

804.3.1.2.8.7.3.1 Airborne position squitter. The airborne position type ES/NT shall use the format DF=18 with the format for register 05 {HEX} as defined in 804.3.1.2.8.6.2 inserted in ME field.

804.3.1.2.8.7.3.2 Surface position squitter. The surface position type ES/NT shall use the format DF=18 with the format for register 06 {HEX} as defined in 804.3.1.2.8.6.2 inserted in ME field.

804.3.1.2.8.7.3.3 Aircraft identification squitter. The aircraft identification type ES/NT shall use the format DF=18 with the format for register 08 {HEX} as defined in 804.3.1.2.8.6.2 inserted in ME field.

804.3.1.2.8.7.3.4 Airborne velocity squitter. The airborne velocity type ES/NT shall use the format DF=18 with the format for register 09 {HEX} as defined in 804.3.1.2.8.6.2 inserted in ME field.

804.3.1.2.8.7.3.5 Event – driven squitter. The event – driven type ES/NT shall use the format DF=18 with the format for register 0A {HEX} as defined in 804.3.1.2.8.6.2 inserted in ME field.

804.3.1.2.8.7.4 ES/NT squitter rate

804.3.1.2.8.7.4.1 Initialization. At power up initialization, the non-transponder device shall commence operation in a mode in which it does not broadcast any squitters. The non-transponder device shall initiate the broadcast of ES/NT squitters for airborne position, surface position, airborne velocity and aircraft identification when data are available for inclusion in the ME field of these squitter types. This determination shall be made individually for each squitter type. When ES/NT squitters are broadcast, transmission rates shall be as indicated in 804.3.1.2.8.6.4.2 to 804.3.1.2.8.6.4.6.

804.3.1.2.8.7.4.2 Delayed transmission. ES/NT squitter transmission shall be delayed if the non-transponder device is busy broadcasting one of the other squitter types.

804.3.1.2.8.7.4.2.1 The delayed squitter shall be transmitted as soon as the non-transponder device becomes available.

804.3.1.2.8.7.5 ES/NT antenna selection. Non-transponder devices operating with antenna diversity (804.3.1.2.10.4) shall transmit ES/NT squitters as follows:

- a) When airborne (804.3.1.2.8.6.7), the non-transponder device shall transmit each type of ES/NT squitter alternately from the two antennas; and
- b) When on the surface (804.3.1.2.8.6.7), the non-transponder device shall transmit ES/NT squitters using the top antenna.

804.3.1.2.8.7.6 Register timeout. The non-transponder device shall clear all 56 bits of the airborne position, surface position and velocity registers used for these messages if these registers are not updated within two seconds of the previous update. This timeout shall be determined separately for each of these registers. Termination of extended squitter broadcast shall be as specified in Annex 10, Volume III, Part I, Appendix 1 to Chapter 5, 2.4.3.

804.3.1.2.8.7.7 Airborne/surface state determination. Aircraft with an automatic means of determining on-the-ground condition shall use this input to select whether to report the airborne or surface message types. Aircraft without such means shall report the airborne type messages.

804.3.1.2.8.7.8 Surface squitter rate control. Once per second the algorithm for aircraft motion specified in Table 2-7 in Annex 10, Volume III, Part I, Appendix 1 to Chapter 5 shall be executed. The surface squitter rate shall be set according to the results of this algorithm.

804.3.1.2.8.8 EXTENDED SQUITTER MILITARY APPLICATION, DOWNLINK FORMAT 19

10011	AF:3	
-------	------	--

804.3.1.2.8.8.1 Military format. The format used for DF = 19 shall be a 112-bit downlink format containing the following fields:

Field	Reference
DF downlink format	804.3.1.2.3.2.1.2
AF control field	804.3.1.2.8.8.2

804.3.1.2.8.8.2 Application field. This 3-bit (6-8) downlink field in DF = 19 shall be used to define the format of the 112-bit transmission.

Code 0 to 7 = Reserved

804.3.1.2.8.9 EXTENDED SQUITTER MAXIMUM TRANSMISSION RATE

804.3.1.2.8.9.1 The maximum total number of extended squitters (DF = 17, 18 or 19) emitted by any extended squitter installation shall not exceed 6.2 per second.

804.3.1.2.9 AIRCRAFT IDENTIFICATION PROTOCOL

804.3.1.2.9.1 Aircraft identification reporting. A ground-initiated Comm-B request (804.3.1.2.6.11.2) containing RR equals 18 and either DI does not equal 7 or DI equals 7 and RRS equals 0 shall cause the resulting reply to contain the aircraft identification in its MB field.

804.3.1.2.9.1.1 AIS, aircraft identification subfield in MB. The transponder shall report the aircraft identification in the 48-bit (41-88) AIS subfield of MB. The aircraft identification transmitted shall be that employed in the flight plan. When no flight plan is available, the registration marking of the aircraft shall be inserted in this subfield.

804.3.1.2.9.1.2 Coding of the AIS subfield. The AIS subfield shall be coded as follows:

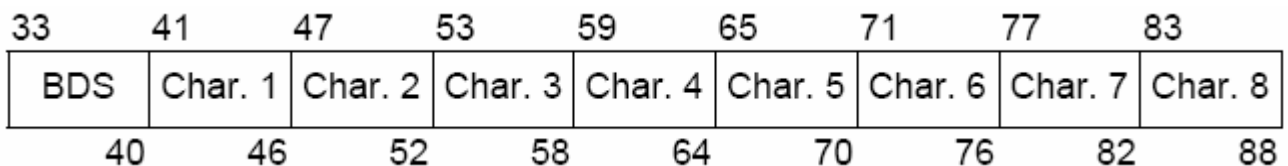

The BDS code for the aircraft identification message shall be BDS1 equals 2 (33-36) and BDS2 equals 0 (37- 40).

Each character shall be coded as a 6-bit subset of the International Alphabet Number 5 (IA-5) as illustrated in Table 3-6. The character code shall be transmitted with the high order unit (b6) first and

the reported aircraft identification shall be transmitted with its left-most character first. Characters shall be coded consecutively without intervening SPACE code. Any unused character spaces at the end of the subfield shall contain a SPACE character code.

804.3.1.2.9.1.3 Aircraft identification capability report. Transponders which respond to a ground-initiated request for aircraft identification shall report this capability in the data link capability report (804.3.1.2.6.10.2.2.2) by setting bit 33 of the MB subfield to 1.

804.3.1.2.9.1.4 Change of aircraft identification. If the aircraft identification reported in the AIS subfield is changed in flight, the transponder shall report the new identification to the ground by use of the Comm-B broadcast message protocol of 804.3.1.2.6.11.4.

804.3.1.2.10 ESSENTIAL SYSTEM CHARACTERISTICS OF THE SSR MODE S TRANSPONDER

804.3.1.2.10.1 Transponder sensitivity and dynamic range. Transponder sensitivity shall be defined in terms of a given interrogation signal input level and a given percentage of corresponding replies. Only correct replies containing the required bit pattern for the interrogation received shall be counted. Given an interrogation that requires a reply according to 804.3.1.2.4, the minimum triggering level, MTL, shall be defined as the minimum input power level for 90 per cent reply-to-interrogation ratio. The MTL shall be  $-74 \text{ dBm} \pm 3 \text{ dB}$ . The reply-to-interrogation ratio of a Mode S transponder shall be:

- a) at least 99 per cent for signal input levels between 3 dB above MTL and  $-21 \text{ dBm}$ ; and
- b) no more than 10 per cent at signal input levels below  $-81 \text{ dBm}$ .

**Table 3-6. Character coding for transmission of aircraft identification by data link**  
 (subset of IA-5 — see 804.3.1.2.9.1.2)

				b6	0	0	1	1
				b5	0	1	0	1
b4	b3	b2	b1					
0	0	0	0			P	SP	0
0	0	0	1		A	Q		1
0	0	1	0		B	R		2
0	0	1	1		C	S		3
0	1	0	0		D	T		4
0	1	0	1		E	U		5
0	1	1	0		F	V		6
0	1	1	1		G	W		7
1	0	0	0		H	X		8
1	0	0	1		I	Y		9
1	0	1	0		J	Z		
1	0	1	1		K			
1	1	0	0		L			
1	1	0	1		M			
1	1	1	0		N			
1	1	1	1		O			

804.3.1.2.10.1.1 Reply ratio in the presence of interference

804.3.1.2.10.1.1.1 Reply ratio in the presence of an interfering pulse. Given a Mode S interrogation which requires a reply (3.1.2.4), the reply ratio of a transponder shall be at least 95 per cent in the presence of an interfering Mode A/C interrogation pulse if the level of the interfering pulse is 6 dB or more below the signal level for Mode S input signal levels between  $-68$  dBm and  $-21$  dBm and the interfering pulse overlaps the P6 pulse of the Mode S interrogation anywhere after the sync phase reversal. Under the same conditions, the reply ratio shall be at least 50 per cent if the interference pulse level is 3 dB or more below the signal level.

804.3.1.2.10.1.1.2 Reply ratio in the presence of pulse pair interference. Given an interrogation which requires a reply (804.3.1.2.4), the reply ratio of a transponder shall be at least 90 per cent in the presence of an interfering P1 - P2 pulse pair if the level of the interfering pulse pair is 9 dB or more below signal level for input signal levels between  $-68$  dBm and  $-21$  dBm and the P1 pulse of the interfering pair occurs no earlier than the P1 pulse of the Mode S signal.

804.3.1.2.10.1.1.3 Reply ratio in the presence of low level asynchronous interference. For all received signals between  $-65$  dBm and  $-21$  dBm and given a Mode S interrogation that requires a reply according to 804.3.1.2.4 and if no lockout condition is in effect, the transponder shall reply correctly with at least 95 per cent reply ratio in the presence of asynchronous interference. Asynchronous interference shall be taken to be a single Mode A/C interrogation pulse occurring at all repetition rates up to 10 000 Hz at a level 12 dB or more below the level of the Mode S signal.

804.3.1.2.10.1.1.4 Spurious response  
The response to signals not within the receiver pass band should be at least 60 dB below normal sensitivity.

804.3.1.2.10.2 Transponder peak pulse power. The peak power of each pulse of a reply shall:

- a) Not be less than 18.5 dBW for aircraft not capable of operating at altitudes exceeding 4 570 m (15 000 ft);
- b) Not be less than 21.0 dBW for aircraft capable of operating above 4 570 m (15 000 ft);
- c) Not be less than 21.0 dBW for aircraft with maximum cruising speed exceeding 324 km/h (175 kt); and
- d) Not exceed 27.0 dBW.

804.3.1.2.10.2.1 Inactive state transponder output power. When the transponder is in the inactive state the peak pulse power at 1 090 MHz plus or minus 3 MHz shall not exceed  $-50$  dBm. The inactive state is defined to include the entire period between transmissions less 10-microsecond transition periods preceding the first pulse and following the last pulse of the transmission.

804.3.1.2.10.2.2 Spurious emission radiation. CW radiation should not exceed 70 dB below 1 watt.

804.3.1.2.10.3 SPECIAL CHARACTERISTICS

Given a Mode S interrogation that requires a reply, the transponder shall:

- a) at all signal levels between MTL +3 dB and -21 dBm, have a reply ratio of less than 10 per cent if the received amplitude of P5 exceeds the received amplitude of P6 by 3 dB or more;
- b) at all signal levels between MTL +3 dB and -21 dBm, have a reply ratio of at least 99 per cent if the received amplitude of P6 exceeds the received amplitude of P5 by 12 dB or more.

804.3.1.2.10.3.2 Mode S dead time. Dead time shall be defined as the time interval beginning at the end of a reply transmission and ending when the transponder has regained sensitivity to within 3 dB of MTL. Mode S transponders shall not have more than 125 microseconds' dead time.

804.3.1.2.10.3.3 Mode S receiver desensitization. The transponder's receiver shall be desensitized according to 804.3.1.1.7.7.1 on receipt of any pulse of more than 0.7 microseconds duration.

804.3.1.2.10.3.3.1 Recovery from desensitization. Recovery from desensitization shall begin at the trailing edge of each pulse of a received signal and shall occur at the rate prescribed in 804.3.1.1.7.7.2, provided that no reply or data transfer is made in response to the received signal.

804.3.1.2.10.3.4 Recovery after Mode S interrogations that do not elicit replies

804.3.1.2.10.3.4.1 Recovery after a single Mode S interrogation

804.3.1.2.10.3.4.1.1 The transponder shall recover sensitivity to within 3 dB of MTL no later than 128 microseconds after receipt of the sync phase reversal following a Mode S interrogation that is not accepted (804.3.1.2.4.1.2) or that is accepted but requires no reply.

804.3.1.2.10.3.4.1.2 The transponder should recover sensitivity to within 3 dB of MTL no later than 45 microseconds after receipt of the sync phase reversal following a Mode S interrogation that is not accepted (804.3.1.2.4.1.2) or that is accepted but requires no reply.

804.3.1.2.10.3.4.1.3 All Mode S transponders installed on or after 1 January 1999 shall recover sensitivity to within 3 dB of MTL no later than 45 microseconds after receipt of the sync phase reversal following a Mode S interrogation that is not accepted (804.3.1.2.4.1.2) or that is accepted but requires no reply.

804.3.1.2.10.3.4.2 Recovery after a Mode S Comm-C interrogation. A Mode S transponder with Comm-C capability shall recover sensitivity to within 3 dB of MTL no later than 45 microseconds after receipt of the sync phase reversal following acceptance of a Comm-C interrogation for which no reply is required.

804.3.1.2.10.3.5 Unwanted Mode S replies. Mode S transponders shall not generate unwanted Mode S replies more often than once in 10 seconds. Installation in the aircraft shall be made in such a manner that this standard shall be achieved when all possible interfering equipments installed in the same aircraft are operating at maximum interference levels.

804.3.1.2.10.3.6 Reply rate limiting

804.3.1.2.10.3.6.1 Mode S reply rate limiting. Reply rate limiting is not required for the Mode S formats of a transponder. If such limiting is incorporated for circuit protection, it shall permit the minimum reply rates required in 804.3.1.2.10.3.7.2 and 804.3.1.2.10.3.7.3.

804.3.1.2.10.3.6.2 Modes A and C reply rate limiting. Reply rate limiting for Modes A and C shall be effected according to 804.3.1.1.7.9.1. The prescribed sensitivity reduction (804.3.1.1.7.9.2) shall not affect the Mode S performance of the transponder.

804.3.1.2.10.3.7 Minimum reply rate capability, Modes A, C and S

804.3.1.2.10.3.7.1 All reply rates specified in 804.3.1.2.10.3.7 shall be in addition to any squitter transmissions that the transponder is required to make.

804.3.1.2.10.3.7.2 Minimum reply rate capability, Modes A and C. The minimum reply rate capability for Modes A and C shall be in accordance with 804.3.1.1.7.9.

804.3.1.2.10.3.7.3 Minimum reply rate capability, Mode S. A transponder capable of transmitting only short Mode S replies shall be able to generate replies at the following rates:

- 50 Mode S replies in any 1-second interval
- 18 Mode S replies in a 100-millisecond interval
- 8 Mode S replies in a 25-millisecond interval
- 4 Mode S replies in a 1.6-millisecond interval

In addition to any downlink ELM transmissions, a level 2, 3 or 4 transponder shall be able to generate as long replies at least:

- 16 of 50 Mode S replies in any 1-second interval
- 6 of 18 Mode S replies in a 100-millisecond interval
- 4 of 8 Mode S replies in a 25-millisecond interval
- 2 of 4 Mode S replies in a 1.6-millisecond interval

In addition to downlink ELM transmissions, a level 5 transponder shall be able to generate as long replies at least:

- 24 of 50 Mode S replies in any 1-second interval
- 9 of 18 Mode S replies in a 100-millisecond interval
- 6 of 8 Mode S replies in a 25-millisecond interval
- 2 of 4 Mode S replies in a 1.6-millisecond interval

In addition, a transponder within an ACAS installation shall be able to generate as ACAS co-ordination replies at least 3 of 50 Mode S replies in any 1-second interval.

804.3.1.2.10.3.7.4 Minimum Mode S ELM peak reply rate

At least once every second a Mode S transponder equipped for ELM downlink operation shall be capable of transmitting in a 25-millisecond interval, at least 25 per cent more segments than have been announced in the initialization (804.3.1.2.7.7.1). The minimum length downlink ELM capability for level 4 and 5 transponders shall be as specified in 804.3.1.2.10.5.2.2.2.

804.3.1.2.10.3.8 Reply delay and jitter

804.3.1.2.10.3.8.1 Reply delay and jitter for Modes A and C. The reply delay and jitter for Modes A and C transactions shall be as prescribed in 804.3.1.1.7.10.

804.3.1.2.10.3.8.2 Reply delay and jitter for Mode S. For all input signal levels between MTL and  $-21$  dBm, the leading edge of the first preamble pulse of the reply (804.3.1.2.2.5.1.1) shall occur 128 plus or minus 0.25 microsecond after the sync phase reversal (804.3.1.2.1.5.2.2) of the received P6. The jitter of the reply delay shall not exceed 0.08 microsecond, peak (99.9 percentile).

804.3.1.2.10.3.8.3 Reply delay and jitter for Modes A/C/S all call. For all input signal levels between MTL +3 dB and  $-21$  dBm the leading edge of the first preamble pulse of the reply (804.3.1.2.2.5.1.1) shall occur 128 plus or minus 0.5 microseconds after the leading edge of the P4 pulse of the interrogation (804.3.1.2.1.5.1.1). Jitter shall not exceed 0.1 microsecond, peak (99.9 percentile).

804.3.1.2.10.3.9 Timers. Duration and features of timers shall be as shown in Table 3-7.  
 All timers shall be capable of being restarted. On receipt of any start command, they shall run for their specified times. This shall occur regardless of whether they are in the running or the non-running state at the time that the start command is received. A command to reset a timer shall cause the timer to stop running and to return to its initial state in preparation for a subsequent start command.

804.3.1.2.10.3.10 Inhibition of replies. Replies to Mode A/C/S all-call and Mode S-only all-call interrogations shall always be inhibited when the aircraft is on the ground. It shall not be possible to inhibit replies to discretely addressed Mode S interrogations, or acquisition squitter transmissions, regardless of whether the aircraft is airborne or on the ground.

804.3.1.2.10.3.10.1 Aircraft should provide means to determine the on-the-ground state automatically and provide that information to the transponder.

804.3.1.2.10.3.10.2 Mode A/C replies should be inhibited when the aircraft is on the ground to prevent interference when in close proximity to an interrogator or other aircraft.

**Table 3-8. Timer characteristics**

<i>Timer</i>				<i>Duration</i>	<i>Tolerance</i>	
<i>Name</i>	<i>Number</i>	<i>Reference</i>	<i>Symbol</i>	<i>s</i>	<i>s</i>	<i>Resettable</i>
Non-selective lock-out	1	3.1.2.6.9.2	$T_D$	18	$\pm 1$	no
Temporary alert	1	3.1.2.6.10.1.1.2	$T_C$	18	$\pm 1$	no
SPI	1	3.1.2.6.10.1.3	$T_I$	18	$\pm 1$	no
Reservations B, C, D	3*	3.1.2.6.11.3.1	$T_R$	18	$\pm 1$	yes
Multisite lockout	78	3.1.2.6.9.1	$T_L$	18	$\pm 1$	no

\* As required

804.3.1.2.10.3.10.3 Inhibition of squitter transmissions. It shall not be possible to inhibit extended squitter transmissions except as specified in 804.3.1.2.8.6 or acquisition squitter transmissions except as specified in 804.3.1.2.8.5 regardless of whether the aircraft is airborne or on the ground.

804.3.1.2.10.4 Transponder antenna system and diversity operation. Mode S transponders equipped for diversity operation shall have two RF ports for operation with two antennas, one antenna on the top and the other on the bottom of the aircraft's fuselage. The received signal from one of the antennas shall be selected for acceptance and the reply shall be transmitted from the selected antenna only.

804.3.1.2.10.4.1 Radiation pattern. The radiation pattern of Mode S antennas when installed on an aircraft shall be nominally equivalent to that of a quarter-wave monopole on a ground plane.

804.3.1.2.10.4.2 Antenna location. The top and bottom antennas shall be mounted as near as possible to the centre line of the fuselage. Antennas shall be located so as to minimize obstruction to their fields in the horizontal plane.

804.3.1.2.10.4.2.1 The horizontal distance between the top and bottom antennas should not be greater than 7.6 m (25 ft).

**Table 3-7. Timer characteristics**

Timer		Reference	Symbol	Duration s	Tolerance s	Resettable
Name	Number					
Non-selective lock-out	1	3.1.2.6.9.2	TD	18	±1	no
Temporary alert	1	3.1.2.6.10.1.1.2	TC	18	±1	no
SPI	1	3.1.2.6.10.1.3	TI	18	±1	no
Reservations B, C, D	3*	3.1.2.6.11.3.1	TR	18	±1	yes
Multisite lockout	78	3.1.2.6.9.1	TL	18	±1	no
* As required						

804.3.1.2.10.4.3 Antenna selection. Mode S transponders equipped for diversity operation shall have the capability to evaluate a pulse sequence simultaneously received on both antenna channels to determine individually for each channel if the P1 pulse and the P2 pulse of a Mode S interrogation preamble meet the requirements for a Mode S interrogation as defined in 804.3.1.2.1 and if the P1 pulse and the P3 pulse of a Mode A, Mode C or intermode interrogation meet the requirements for Mode A and Mode C interrogations as defined in 804.3.1.1.

804.3.1.2.10.4.3.1 If the two channels simultaneously receive at least a P1 - P2 pulse pair that meets the requirements for a Mode S interrogation, or a P1 - P3 pulse pair that meets the requirements for a Mode A or Mode C interrogation, or if the two channels simultaneously accept a complete interrogation, the antenna at which the signal strength is greater shall be selected for the reception of the remainder (if any) of the interrogation and for the transmission of the reply.

804.3.1.2.10.4.3.2 If only one channel receives a pulse pair that meets the requirements for an interrogation, or if only one channel accepts an interrogation, the antenna associated with that channel shall be selected regardless of received signal strength.

804.3.1.2.10.4.3.3 Selection threshold. If antenna selection is based on signal level, it shall be carried out at all signal levels between MTL and -21 dBm.

804.3.1.2.10.4.3.4 Received signal delay tolerance. If an interrogation is received at one antenna 0.125 microsecond or less in advance of reception at the other antenna, the interrogations shall be considered to be simultaneous interrogations, and the above antenna selection criteria applied. If an accepted interrogation is received at either antenna 0.375 microsecond or more in advance of reception at the other antenna, the antenna selected for the reply shall be that which received the earlier interrogation. If the relative time of receipt is between 0.125 and 0.375 microsecond, the transponder shall select the antenna for reply either on the basis of the simultaneous interrogation criteria or on the basis of the earlier time of arrival.



804.3.1.2.10.4.4 Diversity transmission channel isolation. The peak RF power transmitted from the selected antenna shall exceed the power transmitted from the non-selected antenna by at least 20 dB.

804.3.1.2.10.4.5 Reply delay of diversity transponders. The total two-way transmission difference in mean reply delay between the two antenna channels (including the differential delay caused by transponder-to-antenna cables and the horizontal distance along the aircraft centre line between the two antennas) shall not exceed 0.13 microsecond for interrogations of equal amplitude. This requirement shall hold for interrogation signal strengths between MTL +3 dB and -21 dBm. The jitter requirements on each individual channel shall remain as specified for non-diversity transponders.

#### 804.3.1.2.10.5 DATA PROCESSING AND INTERFACES

804.3.1.2.10.5.1 Direct data. Direct data shall be those which are required for the surveillance protocol of the Mode S system.

804.3.1.2.10.5.1.1 Fixed direct data. Fixed direct data are data from the aircraft which do not change in flight and shall be:

- a) The aircraft address (804.3.1.2.4.1.2.3.1.1 and 804.3.1.2.5.2.2.2);
- b) The maximum airspeed (804.3.1.2.8.2.2); and
- c) The registration marking if used for flight identification (804.3.1.2.9.1.1).

804.3.1.2.10.5.1.2 Interfaces for fixed direct data. Interfaces from the transponder to the aircraft should be designed such that the values of the fixed direct data become a function of the aircraft installation rather than of the transponder configuration.

804.3.1.2.10.5.1.3 Variable direct data. Variable direct data are data from the aircraft which may change in flight and shall be:

- a) The Mode C altitude code (804.3.1.2.6.5.4);
- b) The Mode A identity code (804.3.1.2.6.7.1);
- c) The on-the-ground condition (804.3.1.2.6.5.1 and 804.3.1.2.8.2.1);
- d) The aircraft identification if different from the registration marking (804.3.1.2.9.1.1); and
- e) The SPI condition (804.3.1.2.6.10.1.3).

804.3.1.2.10.5.1.4 Interfaces for variable direct data. A means shall be provided for the Mode A identity code, the SPI condition and, for transponders of Level 2 and above, the aircraft identification to be inserted by the pilot via a variable data interface.

Interfaces shall be included to accept the pressure altitude and on-the-ground coding.

804.3.1.2.10.5.2 Indirect data

If origins and/or destinations of indirect data are not within the transponder's enclosure, interfaces shall be used for the necessary connections.

The function of interfaces

804.3.1.2.10.5.2.1.1 Uplink standard length transaction interface. The uplink standard length transaction interface shall transfer all bits of accepted interrogations, (with the possible exception of the AP field), except for UF = 0, 11 or 16.

804.3.1.2.10.5.2.1.2 Downlink standard length transaction interface. A transponder which transmits information originating in a peripheral device shall be able to receive bits or bit patterns for insertion at appropriate locations within the transmission. These locations shall not include those into which bit patterns generated internally by the transponder are inserted, nor the AP field of the reply.  
A transponder which transmits information using the Comm-B format shall have immediate access to requested data in the sense that the transponder shall respond to an interrogation with data requested by that interrogation.

804.3.1.2.10.5.2.2 Indirect data transaction rates

804.3.1.2.10.5.2.2.1 Standard length transactions. A transponder equipped for information transfer to and from external devices shall be capable of processing the data of at least as many replies as prescribed for minimum reply rates in 804.3.1.2.10.3.7.2 and uplink data from interrogations being delivered at a rate of at least:

- 50 long interrogations in any 1-second interval
- 18 long interrogations in a 100-millisecond interval
- 8 long interrogations in a 25-millisecond interval
- 4 long interrogations in a 1.6-millisecond interval.

804.3.1.2.10.5.2.2.2 Extended length transactions. Level 3 (804.2.1.5.1.3) and level 4 (804.2.1.5.1.4) transponders shall be able to transfer data from at least four complete sixteen segment uplink ELMs (804.3.1.2.7.4) in any four second interval. A level 5 transponder (804.2.1.5.1.5) shall be able to transfer the data from at least four complete sixteen segment uplink ELMs in any one second interval and shall be capable of accepting at least two complete sixteen segment uplink ELMs with the same II code in a 250 millisecond interval. A level 4 transponder shall be able to transmit at least one four-segment downlink ELM (804.3.1.2.7.7 and 804.3.1.2.10.3.7.3) in any one second interval.  
A level 5 transponder shall be able to transmit at least one sixteen segment downlink ELM in any one second interval.

804.3.1.2.10.5.2.2.2.1 Level 3 and level 4 transponders should be able to accept at least two complete sixteen segment uplink ELMs in a 250 millisecond interval.

804.3.1.2.10.5.2.3 Data formats for downlink aircraft parameter (DAP) standard length transactions. The downlink standard length transaction interface is used to deliver downlink aircraft parameters (DAPs) to the transponder which makes them available to the ground. Each DAP is packed into the Comm-B format ('MB' field) and can be extracted using either the ground-initiated Comm-B (GICB) protocol, or using MSP downlink channel 3 via the dataflash application (as defined in Annex 10, Volume III, Part I, Appendix 1 to Chapter 5). The formats and update rates of each register used to support DAPs (BDS 1,7; BDS 1,8 to 1,C; BDS 1,D to 1,F; BDS 4,0; BDS 5,0; BDS 6,0) shall be as defined in Annex 10, Volume III, Part I, Appendix 1 to Chapter 5.

804.3.1.2.10.5.3 Integrity of data content transfer. A transponder which employs data interfaces shall include sufficient protection to ensure error rates of less than one error in 103 messages and less than one undetected error in 107 112-bit transmissions in both directions between the antenna and each interface port.

804.3.1.2.10.5.4 Message cancellation. The downlink standard length transaction interface and the extended length message interface shall include the capability to cancel a message sent to the transponder for delivery to the ground, but whose delivery cycle has not been completed (i.e. a closeout has not been accomplished by a ground interrogator).

804.3.1.2.10.5.5 Air-directed messages. The transfer of this type of message requires all of the actions indicated in 804.3.1.2.10.5.4 plus the transfer to the transponder of the interrogator identifier of the site that is to receive the message.

#### 804.3.1.2.11 ESSENTIAL SYSTEM CHARACTERISTICS OF THE GROUND INTERROGATOR

804.3.1.2.11.1 Interrogation repetition rates. Mode S interrogators shall use the lowest practicable interrogation repetition rates for all interrogation modes.

804.3.1.2.11.1.1 All-call interrogation repetition rate. The interrogation repetition rate for the Mode A/C/S all-call, used for acquisition, shall be less than 250 per second. This rate shall also apply to the paired Mode S only and Mode A/C-only all-call interrogations used for acquisition in the multisite mode.

804.3.1.2.11.1.2 Interrogation repetition rate to a single aircraft

804.3.1.2.11.1.2.1 Interrogations requiring a reply. Mode S interrogations requiring a reply shall not be transmitted to a single aircraft at intervals shorter than 400 microseconds.

804.3.1.2.11.1.2.2 Uplink ELM interrogations. The minimum time between the beginning of successive Comm-C interrogations shall be 50 microseconds.

804.3.1.2.11.1.3 Transmission rate for selective interrogations

804.3.1.2.11.1.3.1 For all Mode S interrogators, the transmission rate for selective interrogations shall be:

- a) Less than 2 400 per second averaged over a 40-millisecond interval; and
- b) Less than 480 into any 3-degree sector averaged over a 1-second interval.

804.3.1.2.11.1.3.2 Additionally, for a Mode S interrogator operating with an E-scan that has overlapping coverage with the sidelobes of any other Mode S interrogator, or operating with a rotating antenna, the transmission rate for selective interrogations shall be:

- a) Less than 1 200 per second averaged over a 4-second interval; and
- b) Less than 1 800 per second averaged over a 1-second interval.

#### 804.3.1.2.11.2 INTERROGATOR-EFFECTIVE RADIATED POWER

The effective radiated power of all interrogation pulses should be minimized as described in 804.3.1.1.8.2.

804.3.1.2.11.3 Inactive-state interrogator output power. When the interrogator transmitter is not transmitting an interrogation, its output shall not exceed  $-5$  dBm effective radiated power at any frequency between 960 MHz and 1 215 MHz.

804.3.1.2.11.3.1 Spurious emission radiation. CW radiation should not exceed 76 dB below 1 watt.

804.3.1.2.11.4 Tolerances on transmitted signals. In order that the signal-in-space be received by the transponder as described in 804.3.1.2.1, the tolerances on the transmitted signal shall be as summarized in Table 3-8.

804.3.1.2.11.5 SPURIOUS RESPONSE

The response to signals not within the passband should be at least 60 dB below normal sensitivity.

804.3.1.2.11.6 Lockout co-ordination. A Mode S interrogator shall not be operated using all-call lockout until co-ordination has been achieved with all other operating Mode S interrogators having any overlapping coverage volume in order to ensure that no interrogator can be denied the acquisition of Mode S-equipped aircraft.

804.3.1.2.11.7 MOBILE INTERROGATORS

804.3.1.2.11.7.1 Mobile interrogators should acquire, whenever possible, Mode S aircraft through the reception of squitters.

**Table 3-8. Transmitted signal tolerances**

Reference	Function	Tolerance
804.3.1.2.1.4.1	Pulse duration P1, P2, P3, P4, P5 Pulse duration P6	$\pm 0.09$ microsecond $\pm 0.20$ microsecond
804.3.1.1.4	Pulse duration P1-P3 Pulse duration P1-P2	$\pm 0.18$ microsecond $\pm 0.10$ microsecond
804.3.1.2.1.5.1.3	Pulse duration P3-P4	$\pm 0.04$ microsecond
804.3.1.2.1.5.2.4	Pulse duration P1-P2 Pulse duration P2— sync phase reversal Pulse duration P6— sync phase reversal Pulse duration P5— sync phase reversal	$\pm 0.04$ microsecond $\pm 0.04$ microsecond $\pm 0.04$ microsecond $\pm 0.05$ microsecond
804.3.1.1.5	Pulse amplitude P3	$P1 \pm 0.5$ dB
804.3.1.2.1.5.1.4	Pulse amplitude P4	$P3 \pm 0.5$ dB
804.3.1.2.1.5.2.5	Pulse amplitude P6	Equal to or greater than $P2 - 0.25$ dB
804.3.1.2.1.4.1	Pulse rise times	0.05 microsecond minimum, 0.1 microsecond maximum
804.3.1.2.1.4.1	Pulse decay times	0.05 microsecond minimum, 0.2 microsecond maximum

## 804.4 AIRBORNE COLLISION AVOIDANCE SYSTEM

### 804.4.1 DEFINITIONS RELATING TO AIRBORNE COLLISION AVOIDANCE SYSTEM

**ACAS I.** An ACAS which provides information as an aid to “see and avoid” action but does not include the capability for generating resolution advisories (RAs).

**ACAS II.** An ACAS which provides vertical resolution advisories (RAs) in addition to traffic advisories (TAs).

**ACAS III.** An ACAS which provides vertical and horizontal resolution advisories (RAs) in addition to traffic advisories (TAs).

**ACAS broadcast.** A long Mode S air-air surveillance interrogation (UF = 16) with the broadcast address.

**Active RAC.** An RAC is active if it currently constrains the selection of the RA. RACs that have been received within the last six seconds and have not been explicitly cancelled are active.

**Altitude crossing RA.** A resolution advisory is altitude crossing if own ACAS aircraft is currently at least 30 m (100 ft) below or above the threat aircraft for upward or downward sense advisories, respectively.

**Climb RA.** A positive RA recommending a climb but not an increased climb.

**Closest approach.** The occurrence of minimum range between own ACAS aircraft and the intruder. Thus range at closest approach is the smallest range between the two aircraft and time of closest approach is the time at which this occurs.

**Co-ordination.** The process by which two ACAS-equipped aircraft select compatible resolution advisories (RAs) by the exchange of resolution advisory complements (RACs).

**Co-ordination interrogation.** A Mode S interrogation (uplink transmission) radiated by ACAS II or III and containing a resolution message.

**Co-ordination reply.** A Mode S reply (downlink transmission) acknowledging the receipt of a co-ordination interrogation by the Mode S transponder that is part of an ACAS II or III installation.

**Corrective RA.** A resolution advisory that advises the pilot to deviate from the current flight path.

**Cycle.** The term “cycle” used in this chapter refers to one complete pass through the sequence of functions executed by ACAS II or ACAS III, nominally once a second.

**Descend RA.** A positive RA recommending a descent but not an increased descent.

**Established track.** A track generated by ACAS air-air surveillance that is treated as the track of an actual aircraft.

**Increased rate RA.** A resolution advisory with a strength that recommends increasing the altitude rate to a value exceeding that recommended by a previous climb or descend RA.

**Intruder.** An SSR transponder-equipped aircraft within the surveillance range of ACAS for which ACAS has an established track.

**Own aircraft.** The aircraft fitted with the ACAS that is the subject of the discourse, which ACAS is to protect against possible collisions, and which may enter a manoeuvre in response to an ACAS indication.

**Positive RA.** A resolution advisory that advises the pilot either to climb or to descend (applies to ACAS II).

**Potential threat.** An intruder deserving special attention either because of its close proximity to own aircraft or because successive range and altitude measurements indicate that it could be on a collision or nearcollision course with own aircraft. The warning time provided against a potential threat is sufficiently small that a traffic advisory (TA) is justified but not so small that a resolution advisory (RA) would be justified.

**Preventive RA.** A resolution advisory that advises the pilot to avoid certain deviations from the current flight path but does not require any change in the current flight path.

**RA sense.** The sense of an ACAS II RA is “upward” if it requires climb or limitation of descent rate and “downward” if it requires descent or limitation of climb rate. It can be both upward and downward simultaneously if it requires limitation of the vertical rate to a specified range.

**Resolution advisory (RA).** An indication given to the flight crew recommending:

- a) A manoeuvre intended to provide separation from all threats; or
- b) A manoeuvre restriction intended to maintain existing separation.

**Resolution advisory complement (RAC).** Information provided by one ACAS to another via a Mode S interrogation in order to ensure complementary manoeuvres by restricting the choice of manoeuvres available to the ACAS receiving the RAC.

**Resolution advisory complements record (RAC record).** A composite of all currently active vertical RACs (VRCs) and horizontal RACs (HRCs) that have been received by ACAS. This information is provided by one ACAS to another ACAS or to a Mode S ground station via a Mode S reply.

**Resolution advisory strength.** The magnitude of the manoeuvre indicated by the RA. An RA may take on several successive strengths before being cancelled. Once a new RA strength is issued, the previous one automatically becomes void.

**Resolution message.** The message containing the resolution advisory complement (RAC).

**Reversed sense RA.** A resolution advisory that has had its sense reversed.

**Sensitivity level (S).** An integer defining a set of parameters used by the traffic advisory (TA) and collision avoidance algorithms to control the warning time provided by the potential threat and threat detection logic, as well as the values of parameters relevant to the RA selection logic.

**Threat.** An intruder deserving special attention either because of its close proximity to own aircraft or because successive range and altitude measurements indicate that it could be on a collision or nearcollision course with own aircraft. The warning time provided against a threat is sufficiently small that an RA is justified.

**Track.** A sequence of at least three measurements representing positions that could reasonably have been occupied by an aircraft.

**Traffic advisory (TA).** An indication given to the flight crew that a certain intruder is a potential threat.

**Vertical speed limit (VSL) RA.** A resolution advisory advising the pilot to avoid a given range of altitude rates. A VSL RA can be either corrective or preventive.

**Warning time.** The time interval between potential threat or threat detection and closest approach when neither aircraft accelerates.

## **804.4.2 ACAS I GENERAL PROVISIONS AND CHARACTERISTICS**

804.4.2.1 Functional requirements. ACAS I shall perform the following functions:

- a) Surveillance of nearby SSR transponder-equipped aircraft; and
- b) Provide indications to the flight crew identifying the approximate position of nearby aircraft as an aid to visual acquisition.

804.4.2.2 Signal format. The RF characteristics of all ACAS I signals shall conform to the provisions of Chapter 3, 804.3.1.1.1 through 804.3.1.1.6 and 804.3.1.2.1 through 804.3.1.2.4.

### **804.4.2.3 Interference control**

804.4.2.3.1 Maximum radiated RF power. The effective radiated power of an ACAS I transmission at 0 degree elevation relative to the longitudinal axis of the aircraft shall not exceed 24 dBW.

804.4.2.3.2 Unwanted radiated power. When ACAS I is not transmitting an interrogation, the effective radiated power in any direction shall not exceed -70 dBm.

804.4.2.3.3 Interference limiting. Each ACAS I interrogator shall control its interrogation rate or power or both in all SSR modes to minimize interference effects (804.4.2.3.3.3 and 804.4.2.3.3.4).

804.4.2.3.3.1 Determination of own transponder reply rate. ACAS I shall monitor the rate that own transponder replies to interrogations to ensure that the provisions in 804.4.2.3.3.3 are met.

804.4.2.3.3.2 Determination of the number of ACAS II and ACAS III interrogators. ACAS I shall count the number of ACAS II and ACAS III interrogators in the vicinity to ensure that the provisions in 804.4.2.3.3.3 or 804.4.2.3.3.4 are met. This count shall be obtained by monitoring ACAS broadcasts (UF = 16), (804.4.3.7.1.2.4) and shall be updated as the number of distinct ACAS aircraft addresses received within the previous 20-s period at a nominal frequency of at least 1 Hz.

804.4.2.3.3.3 Mode A/C ACAS I interference limits. The interrogator power shall not exceed the following



$n_a$	Upper limit for $(\sum_{k=1}^{k_r} P_a(k))$	
	If $f_r \leq 240$	If $f_r > 240$
0	250	118
1	250	113
2	250	108
3	250	103
4	250	98
5	250	94
6	250	89
7	250	84
8	250	79
9	250	74
10	245	70
11	228	65
12	210	60
13	193	55
14	175	50
15	158	45
16	144	41
17	126	36
18	109	31
19	91	26
20	74	21
21	60	17
$\geq 22$	42	12

- $n_a$  = number of operating ACAS II and ACAS III equipped aircraft near own (based on ACAS broadcasts received with a transponder receiver threshold of  $-74$  dBm);
- $\{ \}$  = average value of the expression within the brackets over last 16 interrogation cycles;
- $P_a(k)$  = peak power radiated from the antenna in all directions of the pulse having the largest amplitude in the group of pulses comprising a single interrogation during the  $k$ th Mode A/C interrogation in a 1 s interrogation cycle, W;
- $k$  = index number for Mode A/C interrogations,  $k = 1, 2, \dots, k_i$ ;
- $k_i$  = number of Mode A/C interrogations transmitted in a 1 s interrogation cycle;
- $f_r$  = Mode A/C reply rate of own transponder.

804.4.2.3.3.4 Mode SACAS I interface limits. An ACAS I that uses Mode S interrogations shall not cause greater interference effects than ACAS I using Mode A/C interrogation only.

### **804.4.3 GENERAL PROVISIONS RELATING TO ACAS II AND ACAS III**

#### **804.4.3.1 Functional requirements**

804.4.3.1.1 ACAS functions. ACAS shall perform the following functions:

- a) Surveillance;
- b) Generation of TAs;
- c) Threat detection;
- d) Generation of RAs;
- e) Co-ordination; and
- f) Communication with ground stations.

The equipment shall execute functions b) through e) on each cycle of operation.

804.4.3.1.1.1 The duration of a cycle shall not exceed 1.2 s.

#### **804.4.3.2 Surveillance performance requirements**

804.4.3.2.1 General surveillance requirements. ACAS shall interrogate SSR Mode A/C and Mode S transponders in other aircraft and detect the transponder replies. ACAS shall measure the range and relative bearing of

responding aircraft. Using these measurements and information conveyed by transponder replies, ACAS shall estimate the relative positions of each responding aircraft. ACAS shall include provisions for achieving such position determination in the presence of ground reflections, interference and variations in signal strength.

804.4.3.2.1.1 Track establishment probability. ACAS shall generate an established track, with at least a 0.90 probability that the track is established 30 s before closest approach, on aircraft equipped with transponders when all of the following conditions are satisfied:

- a) The elevation angles of these aircraft are within  $\pm 10$  degrees relative to the ACAS aircraft pitch plane;
- b) The magnitudes of these aircraft's rates of change of altitude are less than or equal to 51 m/s (10 000 ft/min);
- c) The transponders and antennas of these aircraft meet the Standards of Chapter 3, 804.3.1.1 and 804.3.1.2;
- d) The closing speeds and directions of these aircraft, the local density of SSR transponder-equipped aircraft and the number of other ACAS interrogators in the vicinity (as determined by monitoring ACAS broadcasts, 804.4.3.7.1.2.4) satisfy the conditions specified in Table 4-1; and
- e) The minimum slant range is equal to or greater than 300 m (1 000 ft).

804.4.3.2.1.1.1 ACAS shall continue to provide surveillance with no abrupt degradation in track establishment probability as any one of the condition bounds defined in 804.4.3.2.1.1 is exceeded.

804.4.3.2.1.1.2 ACAS shall not track Mode S aircraft that report that they are on the ground.

804.4.3.2.1.1.3 ACAS should achieve the required tracking performance when the average SSR Mode A/C asynchronous reply rate from transponders in the vicinity of the ACAS aircraft is 240 replies per second and when the peak interrogation rate received by the individual transponders under surveillance is 500 per second.

**Table 4-1**

<i>Conditions</i>								<i>Performance</i>	
<i>Quadrant</i>						<i>Maximum traffic density</i>		<i>Maximum number of other ACAS within 56 km (30 NM)</i>	<i>Probability of success</i>
<i>Forward</i>		<i>Side</i>		<i>Back</i>					
<i>Maximum closing speed</i>						<i>aircraft/ km<sup>2</sup></i>	<i>aircraft/ NM<sup>2</sup></i>		
<i>m/s</i>	<i>kt</i>	<i>m/s</i>	<i>kt</i>	<i>m/s</i>	<i>kt</i>				
260	500	150	300	93	180	0.087	0.30	30	0.90
620	1 200	390	750	220	430	0.017	0.06	30	0.90

804.4.3.2.1.2 False track probability. The probability that an established Mode A/C track does not correspond in range and altitude, if reported, to an actual aircraft shall be less than 10<sup>-2</sup>. For an established Mode S

track this probability shall be less than  $10^{-6}$ . These limits shall not be exceeded in any traffic environment.

804.4.3.2.1.3 Range and bearing accuracy

804.4.3.2.1.3.1 Range shall be measured with a resolution of 14.5 m (1/128 NM) or better.

804.4.3.2.1.3.2 The errors in the relative bearings of the estimated positions of intruders should not exceed 10 degrees rms.

804.4.3.2.2 INTERFERENCE CONTROL

804.4.3.2.2.1 Maximum radiated RF power. The effective radiated power of an ACAS transmission at 0 degree elevation relative to the longitudinal axis of the aircraft shall not exceed 27 dBW.

804.4.3.2.2.1.1 Unwanted radiated power. When ACAS is not transmitting an interrogation, the effective radiated power in any direction shall not exceed  $-70$  dBm.

804.4.3.2.2.2 Interference limiting. Each ACAS interrogator operating below a pressure altitude of 5 490 m (18 000 ft) shall control its interrogation rate or power or both so as to conform with specific inequalities (804.4.3.2.2.2.2).

804.4.3.2.2.2.1 Determination of the number of other ACAS. ACAS shall count the number of other ACAS II and III interrogators in the vicinity to ensure that the interference limits are met. This count shall be obtained by monitoring ACAS broadcasts (UF = 16), (804.4.3.7.1.2.4). Each ACAS shall monitor such broadcast interrogations to determine the number of other ACAS within detection range.

804.4.3.2.2.2.2 ACAS interference limiting inequalities. ACAS shall adjust its interrogation rate and interrogation power such that the following three inequalities remain true, except as provided in 804.4.3.2.2.2.2.1.

$$\left\{ \sum_{i=1}^{i_t} \left[ \frac{p(i)}{250} \right]^\alpha \right\} < \text{minimum} \left[ \frac{280}{1 + n_a}, \frac{11}{\alpha^2} \right] \quad (1)$$

$$\left\{ \sum_{i=1}^{i_t} m(i) \right\} < 0.01 \quad (2)$$

$$\left\{ \frac{1}{B} \sum_{k=1}^{k_t} \frac{P_a(k)}{250} \right\} < \text{minimum} \left[ \frac{80}{1 + n_a}, 3 \right] \quad (3)$$

The variables in these inequalities shall be defined as follows:

$i_t$  = number of interrogations (Mode A/C and Mode S) transmitted in a 1 s interrogation cycle;

$i$  = index number for Mode A/C and Mode S interrogations,  $i = 1, 2, \dots, i_t$ ;

$\alpha$  = the minimum of  $\alpha_1$  calculated as  $1/4 [n_b/n_c]$  subject to the special conditions given below and  $\alpha_2$  calculated as  $\text{Log}_{10} [n_a / n_b] / \text{Log}_{10} 25$ , where  $n_b$  and  $n_c$  are defined as the number of operating ACAS II and ACAS III equipped aircraft (airborne or on the ground) within 11.2 km (6 NM) and 5.6 km (3 NM) respectively, of own ACAS (based on ACAS surveillance). ACAS aircraft operating at or

below a radio altitude of 610 m (2 000 ft) AGL shall include both airborne and onground ACAS II and ACAS III aircraft in the value for nb and nc. Otherwise, ACAS shall include only airborne ACAS II and ACAS III aircraft in the value for nb and nc. The value of a is further constrained to a minimum of 0.5 and a maximum of 1.0.

In addition;

IF [(nb < 1) OR (nb > 4nc) OR (nb < 4 AND nc < 2 AND na > 25)] THEN  $\alpha_1 = 1.0$ ,

IF [(nc > 2) AND (nb > 2 nc) AND (na < 40)] THEN  $\alpha_1 = 0.5$ ;

p(i) = peak power radiated from the antenna in all directions of the pulse having the largest amplitude in the group of pulses comprising a single interrogation during the ith interrogation in a 1 s interrogation cycle, W;

m(i) = duration of the mutual suppression interval for own transponder associated with the ith interrogation in a 1 s interrogation cycle, s;

B = beam sharpening factor (ratio of 3 dB beamwidth to beamwidth resulting from interrogation side-lobe suppression). For ACAS interrogators that employ transmitter side-lobe suppression (SLS), the appropriate beamwidth shall be the extent in azimuth angle of the Mode A/C replies from one transponder as limited by SLS, averaged over the transponder population;

{ } see 804.4.2.3.3.3

Pa(k) "

K "

Kt "

Na "

804.4.3.2.2.2.2.1 Transmissions during RAs. All air-to-air co-ordination interrogations and RA and ACAS broadcasts shall be transmitted at full power and these interrogations shall be excluded from the summations of Mode S interrogations in the left-hand terms of inequalities (1) and (2) in 804.4.3.2.2.2.2 for the duration of the RA.

804.4.3.2.2.2.2.2 Transmissions from ACAS units on the ground. Whenever the ACAS aircraft indicates that it is on the ground, ACAS interrogations shall be limited by setting the number of other ACAS II and III aircraft (na) count in the interference limiting inequalities to a value that is three times the value obtained based on ACAS broadcasts received with a transponder receiver threshold of -74 dBm. Whenever Mode A/C interrogation power is reduced because of interference limiting, the Mode A/C interrogation power in the forward beam shall be reduced first until the forward sequence matches the right and left sequences. The forward, right and left interrogation powers shall then sequentially be reduced until they match the rear interrogation power. Further reduction of Mode A/C power shall be accomplished by sequentially reducing the forward, side and rear interrogation powers.

804.4.3.2.2.2.2.3 Transmissions from ACAS units above 5 490 m (18 000 ft) altitude. Each ACAS interrogator operating above a pressure altitude of 5 490 m (18 000 ft) shall control its interrogation rate or power or both such that inequalities (1) and (3) in 804.4.3.2.2.2.2 remain true when na and a are equal to 1, except as provided in 804.4.3.2.2.2.1.

### 804.4.3.3 Traffic advisories (TAs)

804.4.3.3.1 TA function. ACAS shall provide TAs to alert the flight crew to potential threats. Such TAs shall be accompanied by an indication of the approximate relative position of potential threats.

804.4.3.3.2 PROXIMATE TRAFFIC DISPLAY

While any RA and/or TA are displayed, proximate traffic within 11 km (6 NM) range and, if altitude reporting,  $\pm 370$  m (1 200 ft) altitude should be displayed. This proximate traffic should be distinguished (e.g. by colour or symbol type) from threats and potential threats, which should be more prominently displayed.

804.4.3.3.3 TAs as RA precursors. The criteria for TAs shall be such that they are satisfied before those for an RA.

804.4.3.3.3.1 TA warning time. For intruders reporting altitude, the nominal TA warning time shall not be greater than  $(T+20)$  s where T is the nominal warning time for the generation of the resolution advisory.

**804.4.3.4 Threat detection**

804.4.3.4.1 Declaration of threat. ACAS shall evaluate appropriate characteristics of each intruder to determine whether or not it is a threat.

804.4.3.4.1.1 Intruder characteristics. As a minimum, the characteristics of an intruder that are used to identify a threat shall include:

- a) Tracked altitude;
- b) Tracked rate of change of altitude;
- c) Tracked slant range;
- d) Tracked rate of change of slant range; and
- e) Sensitivity level of intruder's ACAS, Si.

For an intruder not equipped with ACAS II or ACAS III, Si shall be set to 1.

804.4.3.4.1.2 Own aircraft characteristics. As a minimum, the characteristics of own aircraft that are used to identify a threat shall include:

- a) Altitude;
- b) Rate of change of altitude; and
- c) Sensitivity level of own ACAS (4.3.4.3).

804.4.3.4.2 Sensitivity levels. ACAS shall be capable of operating at any of a number of sensitivity levels. These shall include:

- a) S = 1, a "standby" mode in which the interrogation of other aircraft and all advisories are inhibited;
- b) S = 2, a "TA only" mode in which RAs are inhibited; and
- c) S = 3-7, further levels that enable the issue of RAs that provide the warning times indicated in Table 4-2 as well as TAs.

804.4.3.4.3 Selection of own sensitivity level (So). The selection of own ACAS sensitivity level shall be determined by sensitivity level control (SLC) commands which shall be accepted from a number of sources as follows:

- a) SLC command generated automatically by ACAS based on altitude band or other external factors;
- b) SLC command from pilot input; and
- c) SLC command from Mode S ground stations.

**Table 4-2**

Sensitivity level	2	3	4	5	6	7
Nominal warning time	no RAs	15s	20s	25s	30s	35s

804.4.3.4.3.1 Permitted SLC command codes. As a minimum, the acceptable SLC command codes shall include:

Coding

- for SLC based on altitude band 2-7
- for SLC from pilot input 0,1,2
- for SLC from Mode S ground stations 0,2-6

804.4.3.4.3.2 Altitude-band SLC command. Where ACAS selects an SLC command based on altitude, hysteresis shall be applied to the nominal altitude thresholds at which SLC command value changes are required as follows: for a climbing ACAS aircraft the SLC command shall be increased at the appropriate altitude threshold plus the hysteresis value; for a descending ACAS aircraft the SLC command shall be decreased at the appropriate altitude threshold minus the hysteresis value.

804.4.3.4.3.3 Pilot SLC command. For the SLC command set by the pilot the value 0 shall indicate the selection of the “automatic” mode for which the sensitivity level selection shall be based on the other commands.

804.4.3.4.3.4 Mode S ground station SLC command. For SLC commands transmitted via Mode S ground stations (804.4.3.8.4.2.1.1), the value 0 shall indicate that the station concerned is not issuing an SLC command and that sensitivity level selection shall be based on the other commands, including non-0 commands from other Mode S ground stations. ACAS shall not process an uplinked SLC value of 1.

804.4.3.4.3.4.1 ATS selection of SLC command code. ATS authorities shall ensure that procedures are in place to inform pilots of any ATS selected SLC command code other than 0 (804.4.3.4.3.1).

804.4.3.4.3.5 Selection rule. Own ACAS sensitivity level shall be set to the smallest non-0 SLC command received from any of the sources listed in 804.4.3.4.3.

804.4.3.4.4 Selection of parameter values for RA generation. When the sensitivity level of own ACAS is 3 or greater, the parameter values used for RA generation that depend on sensitivity level shall be based on the greater of the sensitivity level of own ACAS, So, and the sensitivity level of the intruder’s ACAS, Si.

804.4.3.4.5 Selection of parameter values for TA generation. The parameter values used for TA generation that depend on sensitivity level shall be selected on the same basis as those for RAs (804.4.3.4.4) except when an SLC command with a value of 2 (“TA only” mode) has been received from either the pilot or a

Mode S ground station. In this case, the parameter values for TA generation shall retain the values they would have had in the absence of the SLC command from the pilot or Mode S ground station.

#### **804.4.3.5 Resolution advisories (RAs)**

- 804.4.3.5.1 RA generation. For all threats, ACAS shall generate an RA except where it is not possible to select an RA that can be predicted to provide adequate separation either because of uncertainty in the diagnosis of the intruder's flight path or because there is a high risk that a manoeuvre by the threat will negate the RA.
- 804.4.3.5.1.1 RA cancellation. Once an RA has been generated against a threat or threats it shall be maintained or modified until tests that are less stringent than those for threat detection indicate on two consecutive cycles that the RA may be cancelled, at which time it shall be cancelled.
- 804.4.3.5.2 RA selection. ACAS shall generate the RA that is predicted to provide adequate separation from all threats and that has the least effect on the current flight path of the ACAS aircraft consistent with the other provisions in this chapter.
- 804.4.3.5.3 RA effectiveness. The RA shall not recommend or continue to recommend a manoeuvre or manoeuvre restriction that, considering the range of probable threat trajectories, is more likely to reduce separation than increase it, subject to the provisions in 804.4.3.5.5.1.1 and 804.4.3.5.6.
- 804.4.3.5.4 Aircraft capability. The RA generated by ACAS shall be consistent with the performance capability of the aircraft.
- 804.4.3.5.4.1 Proximity to the ground. Descend RAs shall not be generated or maintained when own aircraft is below 300 m (1 000 ft) AGL.
- 804.4.3.5.4.2 ACAS shall not operate in sensitivity levels 3-7 when own aircraft is below 300 m (1 000 ft) AGL.
- 804.4.3.5.5 Reversals of sense. ACAS shall not reverse the sense of an RA from one cycle to the next, except as permitted in 804.4.3.5.5.1 to ensure co-ordination or when the predicted separation at closest approach for the existing sense is inadequate.
- 804.4.3.5.5.1 Sense reversals against equipped threats. If an RAC received from an equipped threat is incompatible with the current RA sense, ACAS shall modify the RA sense to conform with the received RAC if own aircraft address is higher in value than that of the threat.
- 804.4.3.5.5.1.1 ACAS shall not modify an RA sense in a way that makes it incompatible with an RAC received from an equipped threat if own aircraft address is higher in value than that of the threat.
- 804.4.3.5.6 RA strength retention. Subject to the requirement that a descend RA is not generated at low altitude (804.4.3.5.4.1), an RA shall not be modified if the time to closest approach is too short to achieve a significant response or if the threat is diverging in range.
- 804.4.3.5.7 Weakening an RA. An RA shall not be weakened if it is likely that it would subsequently need to be strengthened.
- 804.4.3.5.8 ACAS-equipped threats. The RA shall be compatible with all the RACs transmitted to threats (804.4.3.6.1.3). If an RAC is received from a threat before own ACAS generates an RAC for that threat, the RA generated shall be compatible with the RAC received unless such an RA is more likely to reduce separation than increase it and own aircraft address is lower in value than that of the threat.



804.4.3.5.9 Encoding of ARA subfield. On each cycle of an RA, the RA sense, strength and attributes shall be encoded in the active RA (ARA) subfield (804.4.3.8.4.2.2.1.1). If the ARA subfield has not been refreshed for an interval of 6 s, it shall be set to 0, along with the MTE subfield in the same message (804.4.3.8.4.2.2.1.3).

804.4.3.5.10 System response time. The system delay from receipt of the relevant SSR reply to presentation of an RA sense and strength to the pilot shall be as short as possible and shall not exceed 1.5 s.

#### **804.4.3.6 Co-ordination and communication**

##### 804.4.3.6.1 PROVISIONS FOR CO-ORDINATION WITH ACAS-EQUIPPED THREATS

804.4.3.6.1.1 Multi-aircraft co-ordination. In a multi-aircraft situation, ACAS shall co-ordinate with each equipped threat individually.

804.4.3.6.1.2 Data protection during co-ordination. ACAS shall prevent simultaneous access to stored data by concurrent processes, in particular, during resolution message processing.

804.4.3.6.1.3 Co-ordination interrogation. Each cycle ACAS shall transmit a co-ordination interrogation to each equipped threat, unless generation of an RA is delayed because it is not possible to select an RA that can be predicted to provide adequate separation (804.4.3.5.1). The resolution message transmitted to a threat shall include an RAC selected for that threat. If an RAC has been received from the threat before ACAS selects an RAC for that threat, the selected RAC shall be compatible with the received RAC unless no more than three cycles have elapsed since the RAC was received, the RAC is altitude-crossing, and own aircraft address is lower in value than that of the threat in which case ACAS shall select its RA independently. If an RAC received from an equipped threat is incompatible with the RAC own ACAS has selected for that threat, ACAS shall modify the selected RAC to be compatible with the received RAC if own aircraft address is higher in value than that of the threat.

804.4.3.6.1.3.1 Co-ordination termination. Within the cycle during which an intruder ceases to be a reason for maintaining the RA, ACAS shall send a resolution message to that intruder by means of a co-ordination interrogation. The resolution message shall include the cancellation code for the last RAC sent to that intruder while it was a reason for maintaining the RA.

804.4.3.6.1.3.2 ACAS co-ordination interrogations shall be transmitted until a co-ordination reply is received from the threat, up to a maximum of not less than six and not more than twelve attempts. The successive interrogations shall be nominally equally spaced over a period of  $100 \pm 5$  ms. If the maximum number of attempts is made and no reply is received, ACAS shall continue its regular processing sequence.

804.4.3.6.1.3.3 ACAS shall provide parity protection (804.4.3.8.4.2.3.2.6 and 804.4.3.8.4.2.3.2.7) for all fields in the co-ordination interrogation that convey RAC information.

804.4.3.6.1.3.4 Whenever own ACAS reverses its sense against an equipped threat, the resolution message that is sent on the current and subsequent cycles to that threat shall contain both the newly selected RAC and the cancellation code for the RAC sent before the reversal.

804.4.3.6.1.3.5 When a vertical RA is selected, the vertical RAC (VRC) (804.4.3.8.4.2.3.2.2) that own ACAS includes in a resolution message to the threat shall be as follows:

- a) “do not pass above” when the RA is intended to provide separation above the threat;
- b) “do not pass below” when the RA is intended to provide separation below the threat.

804.4.3.6.1.4 Resolution message processing. Resolution messages shall be processed in the order in which they are received and with delay limited to that required to prevent possible concurrent access to stored data and delays due to the processing of previously received resolution messages. Resolution messages that are being delayed shall be temporarily queued to prevent possible loss of messages. Processing a resolution message shall include decoding the message and updating the appropriate data structures with the information extracted from the message.

804.4.3.6.1.4.1 An RAC or an RAC cancellation received from another ACAS shall be rejected if the encoded sense bits indicate the existence of a parity error or if undefined value(s) are detected in the resolution message. An RAC or an RAC cancellation received without parity errors and without undefined resolution message values shall be considered valid.

804.4.3.6.1.4.2 RAC storage. A valid RAC received from another ACAS shall be stored or shall be used to update the previously stored RAC corresponding to that ACAS. A valid RAC cancellation shall cause the previously stored RAC to be deleted. A stored RAC that has not been updated for an interval of 6 s shall be deleted.

804.4.3.6.1.4.3 RAC record update. A valid RAC or RAC cancellation received from another ACAS shall be used to update the RAC record. If a bit in the RAC record has not been refreshed for an interval of 6 s by any threat, that bit shall be set to 0.

#### 804.4.3.6.2 PROVISIONS FOR ACAS COMMUNICATION WITH GROUND STATIONS

804.4.3.6.2.1 Air-initiated downlink of ACAS RAs. When an ACAS RA exists, ACAS shall:

- a) Transfer to its Mode S transponder an RA report for transmission to the ground in a Comm-B reply (804.4.3.11.4.1); and
- b) Transmit periodic RA broadcasts (804.4.3.7.3.2).

804.4.3.6.2.2 Sensitivity level control (SLC) command. ACAS shall store SLC commands from Mode S ground stations. An SLC command received from a Mode S ground station shall remain effective until replaced by an SLC command from the same ground station as indicated by the site number contained in the IIS subfield of the interrogation. If an existing stored command from a Mode S ground station is not refreshed within 4 minutes, or if the SLC command received has the value 15 (804.4.3.8.4.2.1.1), the stored SLC command for that Mode S ground station shall be set to 0.

#### 804.4.3.6.3 PROVISIONS FOR DATA TRANSFER BETWEEN ACAS AND ITS MODE S TRANSPONDER

804.4.3.6.3.1 Data transfer from ACAS to its Mode S transponder:

- a) ACAS shall transfer RA information to its Mode S transponder for transmission in an RA report (804.4.3.8.4.2.2.1) and in a co-ordination reply (804.4.3.8.4.2.4.2);
- b) ACAS shall transfer current sensitivity level to its Mode S transponder for transmission in a sensitivity level report (804.4.3.8.4.2.5); and

- c) ACAS shall transfer capability information to its Mode S transponder for transmission in a data link capability report (804.4.3.8.4.2.2.2).

804.4.3.6.3.2 Data transfer from Mode S transponder to its ACAS:

- a) ACAS shall receive from its Mode S transponder sensitivity level control commands (804.4.3.8.4.2.1.1) transmitted by Mode S ground stations;
- b) ACAS shall receive from its Mode S transponder ACAS broadcast messages (804.4.3.8.4.2.3.3) transmitted by other ACAS; and
- c) ACAS shall receive from its Mode S transponder resolution messages (804.4.3.8.4.2.3.2) transmitted by other ACAS for air-air co-ordination purposes.

**804.4.3.7 ACAS protocols**

804.4.3.7.1 SURVEILLANCE PROTOCOLS

804.4.3.7.1.1 Surveillance of Mode A/C transponders. ACAS shall use the Mode C-only all-call interrogation (Chapter 3, 804.3.1.2.1.5.1.2) for surveillance of aircraft equipped with Mode A/C transponders.

804.4.3.7.1.2 SURVEILLANCE OF MODE S TRANSPONDERS

804.4.3.7.1.2.1 Detection. ACAS shall detect the presence and determine the address of Mode S-equipped aircraft by monitoring at 1 090 MHz for Mode S all-call replies (DF = 11). The altitude of the Mode S-equipped aircraft shall then be determined either by passively monitoring replies that contain altitude (DF = 0, 4, 16 or 20) received from that aircraft or, if necessary, by interrogating the aircraft with UF = 0.

804.4.3.7.1.2.2 Surveillance interrogations. On first receipt of a 24-bit aircraft address from an aircraft that is determined to be within the reliable surveillance range of ACAS based on reception reliability and that is within an altitude band 3 050 m (10 000 ft) above and below own aircraft, ACAS shall transmit a short air-air interrogation (UF = 0) for range acquisition. Surveillance interrogations shall be transmitted at least once every five cycles when this altitude condition is satisfied. Surveillance interrogations shall be transmitted each cycle if the range of the detected aircraft is less than 5.6 km (3 NM) or the calculated time to closest approach is less than 60 s, assuming that both the detected and own aircraft proceed from their current positions with unaccelerated motion and that the range at closest approach equals 5.6 km (3 NM).

Surveillance interrogations shall be suspended for a period of five cycles if:

- a) A reply was successfully received; and
- b) Own aircraft and intruder aircraft are operating below a pressure altitude of 5 490 m (18 000 ft); and
- c) The range of the detected aircraft is greater than 5.6 km (3 NM) and the calculated time to closest approach exceeds 60 seconds, assuming that both the detected and own aircraft proceed from their current positions with unaccelerated motion and that the range at closest approach equals 5.6 km (3 NM).

804.4.3.7.1.2.2.1 Range acquisition interrogations. ACAS shall use the short air-air surveillance format (UF= 0) for range acquisition. ACAS shall set AQ = 1 (Chapter 3, 804.3.1.2.8.1.1) and RL = 0 (Chapter 3, 804.3.1.2.8.1.2) in an acquisition interrogation.

804.4.3.7.1.2.2.2 Tracking interrogations. ACAS shall use the short air-air surveillance format (UF = 0) with RL = 0 and AQ = 0 for tracking interrogations.

804.4.3.7.1.2.3 Surveillance replies. These protocols are described in 804.4.3.11.3.1.

804.4.3.7.1.2.4 ACAS broadcast. An ACAS broadcast shall be made nominally every 8 to 10 s at full power from the top antenna. Installations using directional antennas shall operate such that complete circular coverage is provided nominally every 8 to 10 s.

#### 804.4.3.7.2 AIR-AIR CO-ORDINATION PROTOCOLS

804.4.3.7.2.1 Co-ordination interrogations. ACAS shall transmit UF = 16 interrogations (Chapter 3, 804.3.1.2.3.2, Figure 3-7) with AQ = 0 and RL = 1 when another aircraft reporting RI = 3 or 4 is declared a threat (804.4.3.4). The MU field shall contain the resolution message in the subfields specified in 804.4.3.8.4.2.3.2.

804.4.3.7.2.2 Co-ordination reply. These protocols are described in 804.4.3.11.3.2.

#### 804.4.3.7.3 PROTOCOLS FOR ACAS COMMUNICATION WITH GROUND STATIONS

804.4.3.7.3.1 RA reports to Mode S ground stations. These protocols are described in 804.4.3.11.4.1.

804.4.3.7.3.2 RA broadcasts. RA broadcasts shall be transmitted at full power from the bottom antenna at jittered, nominally 8 s intervals for the period that the RA is indicated. The RA broadcast shall include the MU field as specified in 804.4.3.8.4.2.3.4. The RA broadcast shall describe the most recent RA that existed during the preceding 8 s period. Installations using directional antennas shall operate such that complete circular coverage is provided nominally every 8 s and the same RA sense and strength is broadcast in each direction.

804.4.3.7.3.3 Data link capability report. These protocols are described in 804.4.3.11.4.2.

804.4.3.7.3.4 ACAS sensitivity level control. ACAS shall act upon an SLC command if and only if TMS (Chapter 3, 804.3.1.2.6.1.4.1) has the value 0 and DI is either 1 or 7 in the same interrogation.

### 804.4.3.8 Signal formats

804.4.3.8.1 The RF characteristics of all ACAS signals shall conform to the Standards of Chapter 3, 804.3.1.1.1 through 804.3.1.1.6, 804.3.1.2.1 through 804.3.1.2.3, 804.3.1.2.5 and 804.3.1.2.8.

#### 804.4.3.8.2 RELATIONSHIP BETWEEN ACAS AND MODE S SIGNAL FORMATS

804.4.3.8.3 Signal format conventions. The data encoding of all ACAS signals shall conform to the Standards of Chapter 3, 804.3.1.2.3.

#### 804.4.3.8.4 FIELD DESCRIPTION

Uplink:

UF = 0	00000	3	RL:1	4	AQ:1	18	AP:24
UF = 16	10000	3	RL:1	4	AQ:1	18	MU:56 AP:24

Downlink:

DF = 0	00000	VS:1	2	SL:3	2	RI:4	2	AC:13	AP:24
DF = 16	10000	VS:1	2	SL:3	2	RI:4	2	AC:13	MV:56 AP:24

**Figure 4-1. Surveillance and communication formats used by ACAS**

804.4.3.8.4.1 FIELDS AND SUBFIELDS INTRODUCED IN CHAPTER 3, 804.3.1.2

804.4.3.8.4.1.1 DR (downlink request). The significance of the coding of the downlink request field shall be as follows:

Coding

- 0 See Chapter 3, 804.3.1.2.6.5.2
- 2 ACAS message available
- 3 Comm-B message available and ACAS message available
- 4-5 See Chapter 3, 804.3.1.2.6.5.2
- 6 Comm-B broadcast message 1 available and ACAS message available
- 7 Comm-B broadcast message 2 available and ACAS message available
- 8-31 See Chapter 3, 804.3.1.2.6.5.2

804.4.3.8.4.1.2 RI (air-air reply information). The significance of the coding in the RI field shall be as follows:

Coding

- 0 No operating ACAS
- 1 Not assigned
- 2 ACAS with resolution capability inhibited
- 3 ACAS with vertical-only resolution capability
- 4 ACAS with vertical and horizontal resolution capability
- 5-7 Not assigned
- 8-15 See Chapter 3, 804.3.1.2.8.2.2

Bit 14 of the reply format containing this field shall replicate the AQ bit of the interrogation. The RI field shall report “no operating ACAS” (RI = 0) if the ACAS unit has failed or is in standby. The RI field shall report “ACAS with resolution capability inhibited” (RI = 2) if sensitivity level is 2 or TA only mode has been selected.

804.4.3.8.4.1.3 RR (reply request). The significance of the coding in the reply request field shall be as follows:

Coding

- 0 See Chapter 3, 804.3.1.2.6.1.2
- 19 Transmit a resolution advisory report
- 20-31 See Chapter 3, 804.3.1.2.6.1.2

804.4.3.8.4.2.1 Subfield in MA

804.4.3.8.4.2.1.1 ADS (A-definition subfield). This 8-bit (33-40) subfield shall define the remainder of MA.

804.4.3.8.4.2.1.2 When ADS1 = 0 and ADS2 = 5, the following subfield shall be contained in MA:

804.4.3.8.4.2.1.3 SLC (ACAS sensitivity level control (SLC) command). This 4-bit (41-44) subfield shall denote a sensitivity level command for own ACAS.

Coding

- 0 No command issued
- 1 Not assigned
- 2 Set ACAS sensitivity level to 2
- 3 Set ACAS sensitivity level to 3
- 4 Set ACAS sensitivity level to 4
- 5 Set ACAS sensitivity level to 5
- 6 Set ACAS sensitivity level to 6
- 7-14 Not assigned
- 15 Cancel previous SLC command from this ground station

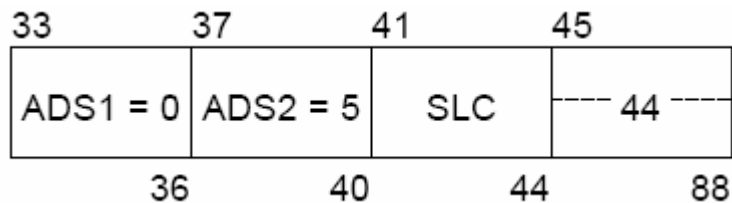

804.4.3.8.4.2.2 Subfields in MB

804.4.3.8.4.2.2.1 Subfields in MB for an RA report. When BDS1 = 3 and BDS2 = 0, the subfields indicated below shall be contained in MB. For  $18 \pm 1$  s following the end of an RA, all MB subfields in the RA report with the exception of bit 59 (RA terminated indicator) shall retain the information reported at the time the RA was last active.

804.4.3.8.4.2.2.1.1 ARA (active RAs). This 14-bit (41-54) subfield shall indicate the characteristics of the RA, if any, generated by the ACAS associated with the transponder transmitting the subfield (804.4.3.6.2.1 a)).

The bits in ARA shall have meanings determined by the value of the MTE subfield (804.4.3.8.4.2.2.1.4) and, for vertical RAs, the value of bit 41 of ARA. The meaning of bit 41 of ARA shall be as follows:

Coding

- 0 There is more than one threat and the RA is intended to provide separation below some threat(s) and above some other threat(s) or no RA has been generated (when MTE = 0)
- 1 Either there is only one threat or the RA is intended to provide separation in the same direction for all threats

When ARA bit 41 = 1 and MTE = 0 or 1, bits 42-47 shall have the following meanings:

<i>Bit</i>	<i>Coding</i>	
42	0	RA is preventive
	1	RA is corrective
43	0	Upward sense RA has been generated
	1	Downward sense RA has been generated
44	0	RA is not increased rate
	1	RA is increased rate
45	0	RA is not a sense reversal
	1	RA is a sense reversal
46	0	RA is not altitude crossing
	1	RA is altitude crossing
47	0	RA is vertical speed limit
	1	RA is positive
48-54		Reserved for ACAS III

When ARA bit 41 = 0 and MTE = 1, bits 42-47 shall have the following meanings:

<i>Bit</i>	<i>Coding</i>	
42	0	RA does not require a correction in the upward sense
	1	RA requires a correction in the upward sense
43	0	RA does not require a positive climb
	1	RA requires a positive climb
44	0	RA does not require a correction in the downward sense
	1	RA requires a correction in the downward sense
45	0	RA does not require a positive descend
	1	RA requires a positive descend
46	0	RA does not require a crossing
	1	RA requires a crossing
47	0	RA is not a sense reversal
	1	RA is a sense reversal
48-54		Reserved for ACAS III

804.4.3.8.4.2.2.1.2 RAC (RACs record). This 4-bit (55-58) subfield shall indicate all the currently active RACs, if any, received from other ACAS aircraft. The bits in RAC shall have the following meanings:

Bit	Resolution advisory complement
55	Do not pass below
56	Do not pass above
57	Do not turn left
58	Do not turn right

A bit set to 1 shall indicate that the associated RAC is active. A bit set to 0 shall indicate that the associated RAC is inactive.

804.4.3.8.4.2.2.1.3 RAT (RA terminated indicator). This 1-bit (59) subfield shall indicate when an RA previously generated by ACAS has ceased being generated.

*Coding*

- 0 ACAS is currently generating the RA indicated in the ARA subfield
- 1 The RA indicated by the ARA subfield has been terminated (804.4.3.11.4.1)

804.4.3.8.4.2.2.1.4 MTE (multiple threat encounter). This 1-bit (60) subfield shall indicate whether two or more simultaneous threats are currently being processed by the ACAS threat resolution logic.

*Coding*

- 0 One threat is being processed by the resolution logic (when ARA bit 41 = 1); or no threat is being processed by the resolution logic (when ARA bit 41 = 0)
- 1 Two or more simultaneous threats are being processed by the resolution logic

804.4.3.8.4.2.2.1.5 TTI (threat type indicator subfield). This 2-bit subfield (61-62) shall define the type of identity data contained in the TID subfield.

*Coding*

- 0 No identity data in TID
- 1 TID contains a Mode S transponder address
- 2 TID contains altitude, range and bearing data
- 3 Not assigned

804.4.3.8.4.2.2.1.6 TID (threat identity data subfield). This 26-bit subfield (63-88) shall contain the Mode S address of the threat or the altitude, range, and bearing if the threat is not Mode S equipped. If two or more threats are simultaneously processed by the ACAS resolution logic, TID shall contain the identity or position data for the most recently declared threat. If TTI = 1, TID shall contain in bits 63-86 the aircraft address of the threat, and bits 87 and 88 shall be set to 0. If TTI = 2, TID shall contain the following three subfields.

804.4.3.8.4.2.2.1.6.1 TIDA (threat identity data altitude subfield). This 13-bit subfield (63-75) shall contain the most recently reported Mode C altitude code of the threat.

*Coding*

Bit	63	64	65	66	67	68	69	70	71	72	73	74	75
Mode C code bit	C <sub>1</sub>	A <sub>1</sub>	C <sub>2</sub>	A <sub>2</sub>	C <sub>4</sub>	A <sub>4</sub>	0	B <sub>1</sub>	D <sub>1</sub>	B <sub>2</sub>	D <sub>2</sub>	B <sub>4</sub>	D <sub>4</sub>

804.4.3.8.4.2.2.1.6.2 TIDR (threat identity data range subfield). This 7-bit subfield (76-82) shall contain the most recent threat range estimated by ACAS.



*Coding (n)*

<i>n</i>	<i>Estimated range (NM)</i>
0	No range estimate available
1	Less than 0.05
2-126	$(n-1)/10 \pm 0.05$
127	Greater than 12.55

804.4.3.8.4.2.2.1.6.3 TIDB (threat identity data bearing subfield). This 6-bit subfield (83-88) shall contain the most recent estimated bearing of the threat aircraft, relative to the ACAS aircraft heading.

*Coding (n)*

<i>n</i>	<i>Estimated bearing (degrees)</i>
0	No bearing estimate available
1-60	Between $6(n-1)$ and $6n$
61-63	Not assigned

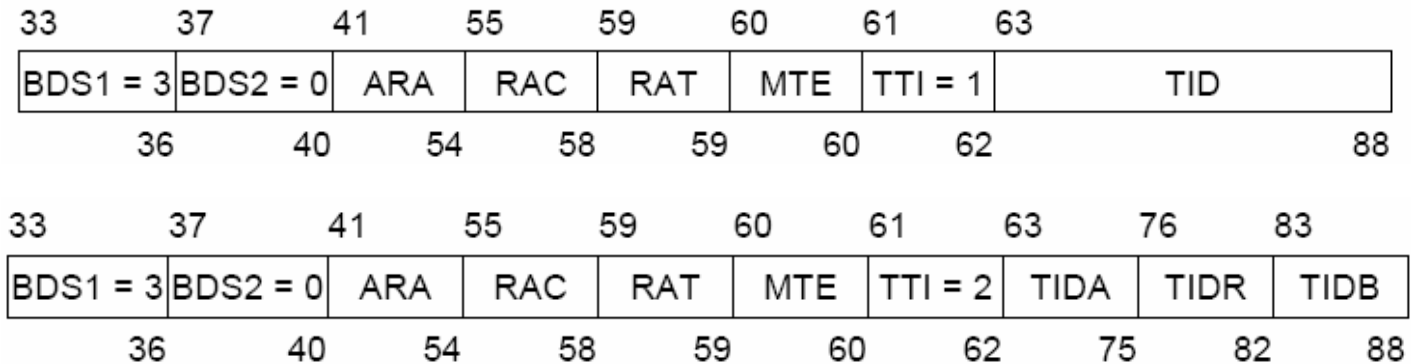

804.4.3.8.4.2.2.2 Subfields in MB for the data link capability report. When BDS1 = 1 and BDS2 = 0, the following bit patterns shall be provided to the transponder for its data link capability report:

<i>Bit</i>	<i>Coding</i>
48	0 ACAS failed or on standby 1 ACAS operating
69	0 ACAS II 1 ACAS III
70	0 ACAS generating TAs only 1 ACAS generating TAs and RAs
71	0 ACAS not fitted 1 ACAS fitted

804.4.3.8.4.2.3 MU field. This 56-bit (33-88) field of long air-air surveillance interrogations (Figure 4-1) shall be used to transmit resolution messages, ACAS broadcasts and RA broadcasts.

804.4.3.8.4.2.3.1 UDS (U-definition subfield). This 8-bit (33-40) subfield shall define the remainder of MU.

804.4.3.8.4.2.3.2 Subfields in MU for a resolution message. When UDS1 = 3 and UDS2 = 0 the following subfields shall be contained in MU:

804.4.3.8.4.2.3.2.1 MTB (multiple threat bit). This 1-bit (42) subfield shall indicate the presence or absence of multiple threats.

*Coding*

- 0 Interrogating ACAS has one threat
- 1 Interrogating ACAS has more than one threat

804.4.3.8.4.2.3.2.2 VRC (vertical RAC). This 2-bit (45-46) subfield shall denote a vertical RAC relating to the addressed aircraft.

*Coding*

- 0 No vertical RAC sent
- 1 Do not pass below
- 2 Do not pass above
- 3 Not assigned

804.4.3.8.4.2.3.2.3 CVC (cancel vertical RAC). This 2-bit (43-44) subfield shall denote the cancellation of a vertical RAC previously sent to the addressed aircraft. This subfield shall be set to 0 for a new threat.

*Coding*

- 0 No cancellation
- 1 Cancel previously sent "Do not pass below"
- 2 Cancel previously sent "Do not pass above"
- 3 Not assigned

804.4.3.8.4.2.3.2.4 HRC (horizontal RAC). This 3-bit (50-52) subfield shall denote a horizontal RAC relating to the addressed aircraft.

*Coding*

- 0 No horizontal RAC or no horizontal resolution capability
- 1 Other ACAS sense is turn left; do not turn left
- 2 Other ACAS sense is turn left; do not turn right
- 3 Not assigned
- 4 Not assigned
- 5 Other ACAS sense is turn right; do not turn left
- 6 Other ACAS sense is turn right; do not turn right
- 7 Not assigned

804.4.3.8.4.2.3.2.5 CHC (cancel horizontal RAC). This 3-bit (47-49) subfield shall denote the cancellation of a horizontal RAC previously sent to the addressed aircraft. This subfield shall be set to 0 for a new threat.

*Coding*

- 0 No cancellation or no horizontal resolution capability
- 1 Cancel previously sent “Do not turn left”
- 2 Cancel previously sent “Do not turn right”
- 3-7 Not assigned

804.4.3.8.4.2.3.2.6 VSB (vertical sense bits subfield). This 4-bit (61-64) subfield shall be used to protect the data in the CVC and VRC subfields. For each of the 16 possible combinations of bits 43-46 the following VSB code shall be transmitted:

<i>Coding</i>	CVC		VRC		VSB			
	43	44	45	46	61	62	63	64
0	0	0	0	0	0	0	0	0
1	0	0	0	1	1	1	1	0
2	0	0	1	0	0	1	1	1
3	0	0	1	1	1	0	0	1
4	0	1	0	0	1	0	1	1
5	0	1	0	1	0	1	0	1
6	0	1	1	0	1	1	0	0
7	0	1	1	1	0	0	1	0
8	1	0	0	0	1	1	0	1
9	1	0	0	1	0	0	1	1
10	1	0	1	0	1	0	1	0
11	1	0	1	1	0	1	0	0
12	1	1	0	0	0	1	1	0
13	1	1	0	1	1	0	0	0
14	1	1	1	0	0	0	0	1
15	1	1	1	1	1	1	1	1

804.4.3.8.4.2.3.2.7 HSB (horizontal sense bits subfield). This 5-bit (56-60) subfield shall be used to protect the data in the CHC and HRC subfields. For each of the 64 possible combinations of bits 47-52 the following HSB code shall be transmitted:

<i>Coding</i>	CHC			HRC			HSB				
	47	48	49	50	51	52	56	57	58	59	60
0	0	0	0	0	0	0	0	0	0	0	0
1	0	0	0	0	0	1	0	1	0	1	1
2	0	0	0	0	1	0	1	0	0	1	1
3	0	0	0	0	1	1	1	1	0	0	0
4	0	0	0	1	0	0	1	1	1	0	0
5	0	0	0	1	0	1	1	0	1	1	1
6	0	0	0	1	1	0	0	1	1	1	1
7	0	0	0	1	1	1	0	0	1	0	0
8	0	0	1	0	0	0	0	1	1	0	1
9	0	0	1	0	0	1	0	0	1	1	0
10	0	0	1	0	1	0	1	1	1	1	0
11	0	0	1	0	1	1	1	0	1	0	1
12	0	0	1	1	0	0	1	0	0	0	1
13	0	0	1	1	0	1	1	1	0	1	0
14	0	0	1	1	1	0	0	0	0	1	0
15	0	0	1	1	1	1	0	1	0	0	1
16	0	1	0	0	0	0	1	0	1	0	1
17	0	1	0	0	0	1	1	1	1	1	0
18	0	1	0	0	1	0	0	0	1	1	0
19	0	1	0	0	1	1	0	1	1	0	1
20	0	1	0	1	0	0	0	1	0	0	1
21	0	1	0	1	0	1	0	0	0	1	0
22	0	1	0	1	1	0	1	1	0	1	0
23	0	1	0	1	1	1	1	0	0	0	1
24	0	1	1	0	0	0	1	1	0	0	0
25	0	1	1	0	0	1	1	0	0	1	1
26	0	1	1	0	1	0	0	1	0	1	1
27	0	1	1	0	1	1	0	0	0	0	0
28	0	1	1	1	0	0	0	0	1	0	0
29	0	1	1	1	0	1	0	1	1	1	1
30	0	1	1	1	1	0	1	0	1	1	1
31	0	1	1	1	1	1	1	1	1	0	0
32	1	0	0	0	0	0	1	1	0	0	1
33	1	0	0	0	0	1	1	0	0	1	0
34	1	0	0	0	1	0	0	1	0	1	0
35	1	0	0	0	1	1	0	0	0	0	1
36	1	0	0	1	0	0	0	0	1	0	1
37	1	0	0	1	0	1	0	1	1	1	0
38	1	0	0	1	1	0	1	0	1	1	0
39	1	0	0	1	1	1	1	1	1	0	1
40	1	0	1	0	0	0	1	0	1	0	0

<i>Coding</i>	CHC			HRC			HSB				
	47	48	49	50	51	52	56	57	58	59	60
41	1	0	1	0	0	1	1	1	1	1	1
42	1	0	1	0	1	0	0	0	1	1	1
43	1	0	1	0	1	1	0	1	1	0	0
44	1	0	1	1	0	0	0	1	0	0	0
45	1	0	1	1	0	1	0	0	0	1	1
46	1	0	1	1	1	0	1	1	0	1	1
47	1	0	1	1	1	1	1	0	0	0	0
48	1	1	0	0	0	0	0	1	1	0	0
49	1	1	0	0	0	1	0	0	1	1	1
50	1	1	0	0	1	0	1	1	1	1	1
51	1	1	0	0	1	1	1	0	1	0	0
52	1	1	0	1	0	0	1	0	0	0	0
53	1	1	0	1	0	1	1	1	0	1	1
54	1	1	0	1	1	0	0	0	0	1	1
55	1	1	0	1	1	1	0	1	0	0	0
56	1	1	1	0	0	0	0	0	0	0	1
57	1	1	1	0	0	1	0	1	0	1	0
58	1	1	1	0	1	0	1	0	0	1	0
59	1	1	1	0	1	1	1	1	0	0	1
60	1	1	1	1	0	0	1	1	1	0	1
61	1	1	1	1	0	1	1	0	1	1	0
62	1	1	1	1	1	0	0	1	1	1	0
63	1	1	1	1	1	1	0	0	1	0	1

804.4.3.8.4.2.3.2.8 MID (Aircraft address). This 24-bit (65-88) subfield shall contain the 24-bit aircraft address of the interrogating ACAS aircraft.

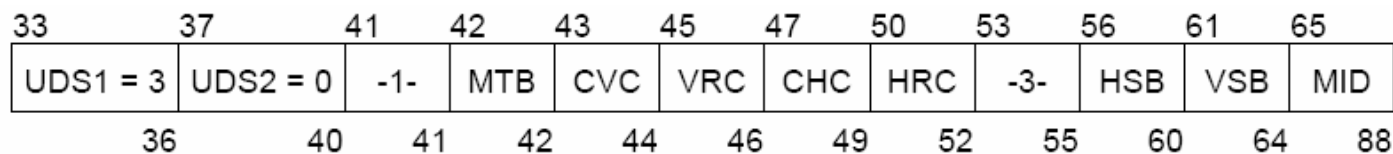

804.4.3.8.4.2.3.3 Subfield in MU for an ACAS broadcast. When UDS1 = 3 and UDS2 = 2, the following subfield shall be contained in MU:

804.4.3.8.4.2.3.3.1 MID (Aircraft address). This 24-bit (65-88) subfield shall contain the 24-bit aircraft address of the interrogating ACAS aircraft.

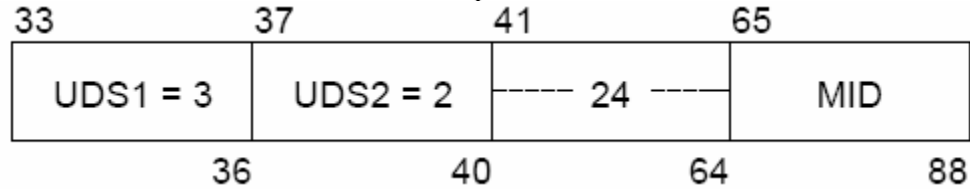

804.4.3.8.4.2.3.4 Subfields in MU for an RA broadcast. When UDS1 = 3 and UDS2 = 1, the following subfields shall be contained in MU:

804.4.3.8.4.2.3.4.1 ARA (active RAs). This 14-bit (41-54) subfield shall be coded as defined in 804.4.3.8.4.2.2.1.1.

804.4.3.8.4.2.3.4.2 RAC (RACs record). This 4-bit (55-58) subfield shall be coded as defined in 804.4.3.8.4.2.2.1.2.

804.4.3.8.4.2.3.4.3 RAT (RA terminated indicator). This 1-bit (59) subfield shall be coded as defined in 804.4.3.8.4.2.2.1.3.

804.4.3.8.4.2.3.4.4 MTE (multiple threat encounter). This 1-bit (60) subfield shall be coded as defined in 804.4.3.8.4.2.2.1.4.

804.4.3.8.4.2.3.4.5 AID (Mode A identity code). This 13-bit (63-75) subfield shall denote the Mode A identity code of the reporting aircraft.

*Coding*

Bit	63	64	65	66	67	68	69	70	71	72	73	74	75
Mode A code bit	C <sub>1</sub>	A <sub>1</sub>	C <sub>2</sub>	A <sub>2</sub>	C <sub>4</sub>	A <sub>4</sub>	0	B <sub>1</sub>	D <sub>1</sub>	B <sub>2</sub>	D <sub>2</sub>	B <sub>4</sub>	D <sub>4</sub>

804.4.3.8.4.2.3.4.6 CAC (Mode C altitude code). This 13-bit (76-88) subfield shall denote the Mode C altitude code of the reporting aircraft.

*Coding*

Bit	76	77	78	79	80	81	82	83	84	85	86	87	88
Mode C code bit	C <sub>1</sub>	A <sub>1</sub>	C <sub>2</sub>	A <sub>2</sub>	C <sub>4</sub>	A <sub>4</sub>	0	B <sub>1</sub>	D <sub>1</sub>	B <sub>2</sub>	D <sub>2</sub>	B <sub>4</sub>	D <sub>4</sub>

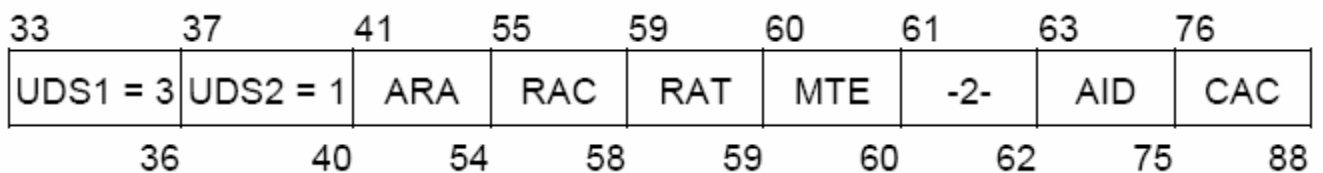

804.4.3.8.4.2.4 MV field. This 56-bit (33-88) field of long air-air surveillance replies (Figure 4-1) shall be used to transmit air-air co-ordination reply messages.

804.4.3.8.4.2.4.1 VDS (V-definition subfield). This 8-bit (33-40) subfield shall define the remainder of MV.

804.4.3.8.4.2.4.2 Subfields in MV for a co-ordination reply. When VDS1 = 3 and VDS2 = 0, the following subfields shall be contained in MV:

804.4.3.8.4.2.4.2.1 ARA (active RAs). This 14-bit (41-54) subfield shall be coded as defined in 804.4.3.8.4.2.2.1.1.

804.4.3.8.4.2.4.2.2 RAC (RACs record). This 4-bit (55-58) subfield shall be coded as defined in 804.4.3.8.4.2.2.1.2.

804.4.3.8.4.2.4.2.3 RAT (RA terminated indicator). This 1-bit (59) subfield shall be coded as defined in 804.4.3.8.4.2.2.1.3.

804.4.3.8.4.2.4.2.4 MTE (multiple threat encounter). This 1-bit (60) subfield shall be coded as defined in 804.4.3.8.4.2.2.1.4.

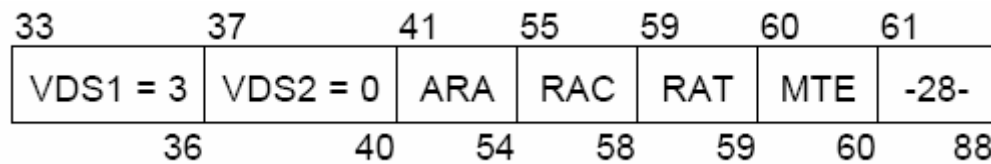

804.4.3.8.4.2.5 SL (sensitivity level report). This 3-bit (9-11) downlink field shall be included in both short and long air-air reply formats (DF = 0 and 16). This field shall denote the sensitivity level at which ACAS is currently operating.

*Coding*

- 0 ACAS inoperative
- 1 ACAS is operating at sensitivity level 1
- 2 ACAS is operating at sensitivity level 2
- 3 ACAS is operating at sensitivity level 3
- 4 ACAS is operating at sensitivity level 4
- 5 ACAS is operating at sensitivity level 5
- 6 ACAS is operating at sensitivity level 6
- 7 ACAS is operating at sensitivity level 7

**804.4.3.9 ACAS equipment characteristics**

804.4.3.9.1 Interfaces. As a minimum, the following input data shall be provided to the ACAS:

- a) Aircraft address code;
- b) Air-air and ground-air Mode S transmissions received by the Mode S transponder for use by ACAS (804.4.3.6.3.2)
- c) Own aircraft's maximum cruising true airspeed capability (Chapter 3, 804.3.1.2.8.2.2);
- d) Pressure altitude; and
- e) Radio altitude.

804.4.3.9.2 Aircraft antenna system. ACAS shall transmit interrogations and receive replies via two antennas, one mounted on the top of the aircraft and the other on the bottom of the aircraft. The top-mounted antenna shall be directional and capable of being used for direction finding.

804.4.3.9.2.1 Polarization. Polarization of ACAS transmissions shall be nominally vertical.

804.4.3.9.2.2 Radiation pattern. The radiation pattern in elevation of each antenna when installed on an aircraft shall be nominally equivalent to that of a quarter-wave monopole on a ground plane.

804.4.3.9.2.3 ANTENNA SELECTION

804.4.3.9.2.3.1 Squitter reception. ACAS shall be capable of receiving squitters via the top and bottom antennas.

804.4.3.9.2.3.2 Interrogations. ACAS interrogations shall not be transmitted simultaneously on both antennas.

804.4.3.9.3 Pressure altitude source. The altitude data for own aircraft provided to ACAS shall be obtained from the source that provides the basis for own Mode C or Mode S reports and they shall be provided at the finest quantization available.

804.4.3.9.3.1 A source providing a resolution finer than 7.62 m (25 ft) should be used.

804.4.3.9.3.2 Where a source providing a resolution finer than 7.62 m (25 ft) is not available, and the only altitude data available for own aircraft is Gilham encoded, at least two independent sources shall be used and compared continuously in order to detect encoding errors.

804.4.3.9.3.3 Two altitude data sources should be used and compared in order to detect errors before provision to ACAS.

804.4.3.9.3.4 The provisions of 804.4.3.10.3 shall apply when the comparison of the two altitude data sources indicates that one of the sources is in error.

#### **804.4.3.10 Monitoring**

804.4.3.10.1 Monitoring function. ACAS shall continuously perform a monitoring function in order to provide a warning if any of the following conditions at least are satisfied:

a) There is no interrogation power limiting due to interference control (804.4.3.2.2.2) and the maximum radiated power is reduced to less than that necessary to satisfy the surveillance requirements specified in 804.4.3.2; or

b) Any other failure in the equipment is detected which results in a reduced capability of providing TAs or RAs; or

c) Data from external sources indispensable for ACAS operation are not provided, or the data provided are not credible.

804.4.3.10.2 Effect on ACAS operation. The ACAS monitoring function shall not adversely affect other ACAS functions.

804.4.3.10.3 Monitoring response. When the monitoring function detects a failure (4.3.10.1), ACAS shall:



- a) Indicate to the flight crew that an abnormal condition exists;
- b) Prevent any further ACAS interrogations; and
- c) Cause any Mode S transmission containing own aircraft's resolution capability to indicate that ACAS is not operating.

#### **804.4.3.11 Requirements for a Mode S transponder used in conjunction with ACAS**

804.4.3.11.1 Transponder capabilities. In addition to the minimum transponder capabilities defined in Chapter 3, 804.3.1, the Mode S transponder used in conjunction with ACAS shall have the following capabilities:

- a) Ability to handle the following formats:

Format No.	Format name
UF = 16	Long air-air surveillance interrogation
DF = 16	Long air-air surveillance reply
- b) Ability to receive long Mode S interrogations (UF = 16) and generate long Mode S replies (DF = 16) at a continuous rate of 16.6 ms (60 per second);
- c) Means for delivering the ACAS data content of all accepted interrogations addressed to the ACAS equipment;
- d) Antenna diversity (as specified in Chapter 3, 804.3.1.2.10.4);
- e) Mutual suppression capability; and
- f) Inactive state transponder output power restriction.

When the Mode S transponder transmitter is in the inactive state, the peak pulse power at 1 090 MHz  $\pm$ 3MHz at the terminals of the Mode S transponder antenna shall not exceed  $-70$  dBm.

#### **804.4.3.11.2 DATA TRANSFER BETWEEN ACAS AND ITS MODE S TRANSPONDER**

804.4.3.11.2.1 Data transfer from ACAS to its Mode S transponder:

- a) The Mode S transponder shall receive from its ACAS RA information for transmission in an RA report (804.4.3.8.4.2.2.1) and in a co-ordination reply (804.4.3.8.4.2.4.2);
- b) The Mode S transponder shall receive from its ACAS current sensitivity level for transmission in a sensitivity level report (804.4.3.8.4.2.5);
- c) The Mode S transponder shall receive from its ACAS capability information for transmission in a data link capability report (804.4.3.8.4.2.2.2) and for transmission in the RI field of air-air downlink formats DF = 0 and DF = 16 (804.4.3.8.4.1.2); and
- d) The Mode S transponder shall receive from its ACAS an indication that RAs are enabled or inhibited for transmission in the RI field of downlink formats 0 and 16.

804.4.3.11.2.2 Data transfer from Mode S transponder to its ACAS:

- a) The Mode S transponder shall transfer to its ACAS received sensitivity level control commands (804.4.3.8.4.2.1.1) transmitted by Mode S stations;
- b) The Mode S transponder shall transfer to its ACAS received ACAS broadcast messages (804.4.3.8.4.2.3.3) transmitted by other ACASs;
- c) The Mode S transponder shall transfer to its ACAS received resolution messages (804.4.3.8.4.2.3.2) transmitted by other ACASs for air-air co-ordination purposes; and
- d) The Mode S transponder shall transfer to its ACAS own aircraft's Mode A identity data for transmission in an RA broadcast (804.4.3.8.4.2.3.4.5).

#### 804.4.3.11.3 COMMUNICATION OF ACAS INFORMATION TO OTHER ACAS

804.4.3.11.3.1 Surveillance reply. The ACAS Mode S transponder shall use the short (DF = 0) or long (DF = 16) surveillance formats for replies to ACAS surveillance interrogations. The surveillance reply shall include the VS field as specified in Chapter 3, 804.3.1.2.8.2, the RI field as specified in Chapter 3, 804.3.1.2.8.2 and in 804.4.3.8.4.1.2, and the SL field as specified in 804.4.3.8.4.2.5.

804.4.3.11.3.2 Co-ordination reply. The ACAS Mode S transponder shall transmit a co-ordination reply upon receipt of a co-ordination interrogation from an equipped threat subject to the conditions of 804.4.3.11.3.2.1. The co-ordination reply shall use the long air-air surveillance reply format, DF = 16, with the VS field as specified in Chapter 3, 804.3.1.2.8.2, the RI field as specified in Chapter 3, 804.3.1.2.8.2 and in 804.4.3.8.4.1.2, the SL field as specified in 804.4.3.8.4.2.5 and the MV field as specified in 804.4.3.8.4.2.4. Co-ordination replies shall be transmitted even if the minimum reply rate limits of the transponder (Chapter 3, 804.3.1.2.10.3.7.2) are exceeded.

804.4.3.11.3.2.1 The ACAS Mode S transponder shall reply with a co-ordination reply to a co-ordination interrogation received from another ACAS if and only if the transponder is able to deliver the ACAS data content of the interrogation to its associated ACAS.

#### 804.4.3.11.4 COMMUNICATION OF ACAS INFORMATION TO GROUND STATIONS

804.4.3.11.4.1 RA reports to Mode S ground stations. During the period of an RA and for  $18 \pm 1$  s following the end of the RA, the ACAS Mode S transponder shall indicate that it has an RA report by setting the appropriate DR field code in replies to a Mode S sensor as specified in 804.4.3.8.4.1.1. The RA report shall include the MB field as specified in 804.4.3.8.4.2.2.1. The RA report shall describe the most recent RA that existed during the preceding  $18 \pm 1$  s period.

804.4.3.11.4.2 Data link capability report. The presence of an ACAS shall be indicated by its Mode S transponder to a ground station in the Mode S data link capability report.

#### **804.4.3.12 Indications to the flight crew**

804.4.3.12.1 CORRECTIVE AND PREVENTIVE RAS. Indications to the flight crew should distinguish between preventive and corrective RAs.

804.4.3.12.2 ALTITUDE CROSSING RAS. If ACAS generates an altitude crossing RA, a specific indication should be given to the flight crew that it is crossing.

**804.4.4 PERFORMANCE OF THE ACAS II COLLISION AVOIDANCE LOGIC**

**804.4.4.1 Definitions relating to the performance of the collision avoidance logic**

**Altitude layer.** Each encounter is attributed to one of six altitude layers as follows:

<i>Layer</i>	<i>1</i>	<i>2</i>	<i>3</i>	<i>4</i>	<i>5</i>	<i>6</i>
<i>from</i>		2 300 ft	5 000 ft	10 000 ft	20 000 ft	41 000 ft
<i>to</i>	2 300 ft	5 000 ft	10 000 ft	20 000 ft	41 000 ft	

The altitude layer of an encounter is determined by the average altitude of the two aircraft at closest approach.

**Approach angle.** The difference in the ground headings of the two aircraft at closest approach, with 180 degrees defined as head on and 0 degrees defined as parallel.

**Crossing encounter.** An encounter in which the altitude separation of the two aircraft exceeds 100 ft at the beginning and at the end of the encounter window, and the relative vertical position of two aircraft at the end of the encounter window is reversed from that at the beginning of the encounter window.

**Encounter.** For the purposes of defining the performance of the collision avoidance logic, an encounter consists of two simulated aircraft trajectories. The horizontal coordinates of the aircraft represent the actual position of the aircraft but the vertical coordinate represents an altimeter measurement of altitude.

**Encounter class.** Encounters are classified according to whether or not the aircraft are transitioning at the beginning and end of the encounter window, and whether or not the encounter is crossing.

**Encounter window.** The time interval [ $tca - 40$  s,  $tca + 10$  s].

**Horizontal miss distance (hmd).** The minimum horizontal separation observed in an encounter.

**Level aircraft.** An aircraft that is not transitioning.

**Original trajectory.** The original trajectory of an ACAS-equipped aircraft is that followed by the aircraft in the same encounter when it was not ACAS equipped.

**Original rate.** The original rate of an ACAS-equipped aircraft at any time is its altitude rate at the same time when it followed the original trajectory.

**Required rate.** For the standard pilot model, the required rate is that closest to the original rate consistent with the RA.

**tca.** Nominally, the time of closest approach. For encounters in the standard encounter model (804.4.4.2.6), a reference time for the construction of the encounter at which various parameters, including the vertical and horizontal separation (vmd and hmd), are specified.

**Transitioning aircraft.** An aircraft having an average vertical rate with a magnitude exceeding 400 ft per minute (ft/min), measured over some period of interest.

**Turn extent.** A heading difference defined as an aircraft's ground heading at the end of a turn minus its ground heading at the beginning of the turn.

**Vertical miss distance (vmd).** Notionally, the vertical separation at closest approach. For encounters in the standard encounter model (804.4.4.2.6), by construction the vertical separation at the time tca.

#### **804.4.4.2 Conditions under which the requirements apply**

804.4.4.2.1 The following assumed conditions shall apply to the performance requirements specified in 804.4.4.3 and 804.4.4.4:

- a) Range and bearing measurements and an altitude report are available for the intruder each cycle as long as it is within 14 NM, but not when the range exceeds 14 NM;
- b) The errors in the range and bearing measurements conform to standard range and bearing error models (804.4.4.2.2 and 804.4.4.2.3);
- c) The intruder's altitude reports, which are its Mode C replies, are expressed in 100 ft quanta;
- d) An altitude measurement that has not been quantized and is expressed with a precision of 1 ft or better is available for own aircraft;
- e) Errors in the altitude measurements for both aircraft are constant throughout any particular encounter;
- f) The errors in the altitude measurements for both aircraft conform to a standard altimetry error model (804.4.4.2.4);
- g) The pilot responses to RAs conform to a standard pilot model (804.4.4.2.5);
- h) The aircraft operate in an airspace in which close encounters, including those in which ACAS generates an RA, conform to a standard encounter model (804.4.4.2.6);
  - i) ACAS-equipped aircraft are not limited in their ability to perform the manoeuvres required by their RAs; and
  - j) As specified in 804.4.4.2.7:
    - 1) the intruder involved in each encounter is not equipped (804.4.4.2.7 a)); or
    - 2) the intruder is ACAS-equipped but follows a trajectory identical to that in the unequipped encounter (804.4.4.2.7 b)); or
    - 3) the intruder is equipped with an ACAS having a collision avoidance logic identical to that of own ACAS (804.4.4.2.7 c)).

804.4.4.2.1.1 The performance of the collision avoidance logic shall not degrade abruptly as the statistical distribution of the altitude errors or the statistical distributions of the various parameters that characterize the standard encounter model or the response of pilots to the advisories are varied, when surveillance reports are not available on every cycle or when the quantization of the altitude measurements for the intruder is varied or the altitude measurements for own aircraft are quantized.

804.4.4.2.2 STANDARD RANGE ERROR MODEL

804.4.4.2.2.1 The errors in the simulated range measurements shall be taken from a Normal distribution with mean 0 ft and standard deviation 50 ft.

804.4.4.2.3 STANDARD BEARING ERROR MODEL

804.4.4.2.3.1 The errors in the simulated bearing measurements shall be taken from a Normal distribution with mean 0.0 degrees and standard deviation 10.0 degrees.

804.4.4.2.4 STANDARD ALTIMETRY ERROR MODEL

804.4.4.2.4.1 The errors in the simulated altitude measurements shall be assumed to be distributed as a Laplacian distribution with zero mean having probability density

$$p(e) = \frac{1}{2\lambda} \exp\left(-\frac{|e|}{\lambda}\right)$$

804.4.4.2.4.2 The parameter  $\lambda$  required for the definition of the statistical distribution of altimeter error for each aircraft shall have one of two values,  $\lambda_1$  and  $\lambda_2$ , which depend on the altitude layer of the encounter as follows:

<i>Layer</i>	<i>1</i>		<i>2</i>		<i>3</i>		<i>4</i>		<i>5</i>		<i>6</i>	
	<i>m</i>	<i>ft</i>	<i>m</i>	<i>ft</i>	<i>m</i>	<i>ft</i>	<i>m</i>	<i>ft</i>	<i>m</i>	<i>ft</i>	<i>m</i>	<i>ft</i>
$\lambda_1$	10	35	11	38	13	43	17	58	22	72	28	94
$\lambda_2$	18	60	18	60	21	69	26	87	30	101	30	101

804.4.4.2.4.3 For an aircraft equipped with ACAS the value of  $\lambda$  shall be  $\lambda_1$ .

804.4.4.2.4.4 For aircraft not equipped with ACAS, the value of  $\lambda$  shall be selected randomly using the following probabilities:

<i>Layer</i>	<i>1</i>	<i>2</i>	<i>3</i>	<i>4</i>	<i>5</i>	<i>6</i>
prob( $\lambda_1$ )	0.391	0.320	0.345	0.610	0.610	0.610
prob( $\lambda_2$ )	0.609	0.680	0.655	0.390	0.390	0.390

804.4.4.2.5 STANDARD PILOT MODEL

804.4.4.2.5.1 The standard pilot model used in the assessment of the performance of the collision avoidance logic shall be that:

- a) Any RA is complied with by accelerating to the required rate (if necessary) after an appropriate delay;
- b) When the aircraft's current rate is the same as its original rate and the original rate complies with the RA, the aircraft continues at its original rate, which is not necessarily constant due to the possibility of acceleration in the original trajectory;

- c) When the aircraft is complying with the RA, its current rate is the same as the original rate and the original rate changes and consequently becomes inconsistent with the RA, the aircraft continues to comply with the RA;
- d) When an initial RA requires a change in altitude rate, the aircraft responds with an acceleration of 0.25 g after a delay of 5 s from the display of the RA;
- e) When an RA is modified and the original rate complies with the modified RA, the aircraft returns to its original rate (if necessary) with the acceleration specified in g) after the delay specified in h);
- f) When an RA is modified and the original rate does not comply with the modified RA, the aircraft responds to comply with the RA with the acceleration specified in g) after the delay specified in h);
- g) The acceleration used when an RA is modified is 0.25 g unless the modified RA is a reversed sense RA or an increased rate RA in which case the acceleration is 0.35 g;
- h) The delay used when an RA is modified is 2.5 s unless this results in the acceleration starting earlier than 5 s from the initial RA in which case the acceleration starts 5 s from the initial RA; and
- i) When an RA is cancelled, the aircraft returns to its original rate (if necessary) with an acceleration of 0.25 g after a delay of 2.5 s.

#### 804.4.4.2.6 STANDARD ENCOUNTER MODEL

##### 804.4.4.2.6.1 ELEMENTS OF THE STANDARD ENCOUNTER MODEL

804.4.4.2.6.1.1 In order to calculate the effect of ACAS on the risk of collision (804.4.4.3) and the compatibility of ACAS with air traffic management (ATM) (804.4.4.4), sets of encounters shall be created for each of:

- a) The two aircraft address orderings;
- b) The six altitude layers;
- c) Nineteen encounter classes; and
- d) Nine or ten vmd bins as specified in 804.4.4.2.6.2.4.

The results for these sets shall be combined using the relative weightings given in 804.4.4.2.6.2.

804.4.4.2.6.1.1.1 Each set of encounters shall contain at least 500 independent, randomly generated encounters.

804.4.4.2.6.1.2 The two aircraft trajectories in each encounter shall be constructed with the following randomly selected characteristics:

- a) In the vertical plane:
  - 1) a vmd from within the appropriate vmd bin;
  - 2) a vertical rate for each aircraft at the beginning of the encounter window, , and at the end of the 0 z1 encounter window, ; 0 z2

- 3) a vertical acceleration; and
- 4) a start time for the vertical acceleration; and

b) And in the horizontal plane:

- 1) an hmd;
- 2) an approach angle;
- 3) a speed for each aircraft at closest approach;
- 4) a decision for each aircraft whether or not it turns;
- 5) the turn extent; the bank angle; and the turn end time;
- 6) a decision for each aircraft whether or not its speed changes; and
- 7) the magnitude of the speed change.

804.4.4.2.6.1.3 Two models shall be used for the statistical distribution of hmd (804.4.4.2.6.4.1). For calculations of the effect of ACAS on the risk of collision (804.4.4.3), hmd shall be constrained to be less than 500 ft. For calculations of the compatibility of ACAS with ATM (804.4.4.4), hmd shall be selected from a larger range of values (804.4.4.2.6.4.1.2).

804.4.4.2.6.2 ENCOUNTER CLASSES AND WEIGHTS

804.4.4.2.6.2.1 Aircraft address. Each aircraft shall be equally likely to have the higher aircraft address.

804.4.4.2.6.2.2 Altitude layers. The relative weights of the altitude layers shall be as follows:

<i>Layer</i>	<i>1</i>	<i>2</i>	<i>3</i>	<i>4</i>	<i>5</i>	<i>6</i>
prob(layer)	0.13	0.25	0.32	0.22	0.07	0.01

804.4.4.2.6.2.3 Encounter classes

804.4.4.2.6.2.3.1 The encounters shall be classified according to whether the aircraft are level (L) or transitioning (T) at the beginning (before tca) and end (after tca) of the encounter window and whether or not the encounter is crossing, as follows:

<i>Class</i>	<i>Aircraft No. 1</i>		<i>Aircraft No. 2</i>		<i>Crossing</i>
	<i>before tca</i>	<i>after tca</i>	<i>before tca</i>	<i>after tca</i>	
1	L	L	T	T	yes
2	L	L	L	T	yes
3	L	L	T	L	yes
4	T	T	T	T	yes
5	L	T	T	T	yes
6	T	T	T	L	yes
7	L	T	L	T	yes
8	L	T	T	L	yes
9	T	L	T	L	yes

<i>Class</i>	<i>Aircraft No. 1</i>		<i>Aircraft No. 2</i>		<i>Crossing</i>
	<i>before tca</i>	<i>after tca</i>	<i>before tca</i>	<i>after tca</i>	
10	L	L	L	L	no
11	L	L	T	T	no
12	L	L	L	T	no
13	L	L	T	L	no
14	T	T	T	T	no
15	L	T	T	T	no
16	T	T	T	L	no
17	L	T	L	T	no
18	L	T	T	L	no
19	T	L	T	L	no

804.4.4.2.6.2.3.2 The relative weights of the encounter classes shall depend on layer as follows:

<i>Class</i>	<i>for calculating risk ratio</i>		<i>for ATM compatibility</i>	
	<i>Layers 1-3</i>	<i>Layers 4-6</i>	<i>Layers 1-3</i>	<i>Layers 4-6</i>
1	0.00502	0.00319	0.06789	0.07802
2	0.00030	0.00018	0.00408	0.00440
3	0.00049	0.00009	0.00664	0.00220
4	0.00355	0.00270	0.04798	0.06593
5	0.00059	0.00022	0.00791	0.00549
6	0.00074	0.00018	0.00995	0.00440
7	0.00002	0.00003	0.00026	0.00082
8	0.00006	0.00003	0.00077	0.00082
9	0.00006	0.00003	0.00077	0.00082
10	0.36846	0.10693	0.31801	0.09011
11	0.26939	0.41990	0.23252	0.35386
12	0.06476	0.02217	0.05590	0.01868
13	0.07127	0.22038	0.06151	0.18571
14	0.13219	0.08476	0.11409	0.07143
15	0.02750	0.02869	0.02374	0.02418
16	0.03578	0.06781	0.03088	0.05714
17	0.00296	0.00098	0.00255	0.00082
18	0.00503	0.00522	0.00434	0.00440
19	0.01183	0.03651	0.01021	0.03077



804.4.4.2.6.2.4.1 The vmd of each encounter shall be taken from one of ten vmd bins for the non-crossing encounter classes, and from one of nine or ten vmd bins for the crossing encounter classes. Each vmd bin shall have an extent of 100 ft for calculating risk ratio, or an extent of 200 ft for calculating compatibility with ATM. The maximum vmd shall be 1 000 ft for calculating risk ratio, and 2 000 ft otherwise.

804.4.4.2.6.2.4.2 For non-crossing encounter classes, the relative weights of the vmd bins shall be as follows:

<i>vmd bin</i>	<i>for calculating risk ratio</i>	<i>for ATM compatibility</i>
1	0.013	0.128
2	0.026	0.135
3	0.035	0.209
4	0.065	0.171
5	0.100	0.160
6	0.161	0.092
7	0.113	0.043
8	0.091	0.025
9	0.104	0.014
10	0.091	0.009

804.4.4.2.6.2.4.3 For the crossing classes, the relative weights of the vmd bins shall be as follows:

<i>vmd bin</i>	<i>for calculating risk ratio</i>	<i>for ATM compatibility</i>
1	0.0	0.064
2	0.026	0.144
3	0.036	0.224
4	0.066	0.183
5	0.102	0.171
6	0.164	0.098
7	0.115	0.046
8	0.093	0.027
9	0.106	0.015
10	0.093	0.010

804.4.4.2.6.3 CHARACTERISTICS OF THE AIRCRAFT TRAJECTORIES IN THE VERTICAL PLANE

804.4.4.2.6.3.1 vmd. The vmd for each encounter shall be selected randomly from a distribution that is uniform in the interval covered by the appropriate vmd bin.

804.4.4.2.6.3.2 Vertical rate

804.4.4.2.6.3.2.1 For each aircraft in each encounter, either the vertical rate shall be constant ) or the vertical trajectory shall be constructed so that the vertical rate at  $tca - 35$  s is  $z1$  and the vertical rate at  $tca + 5$  s is  $z2$  Each vertical rate,  $z$ ,  $z1$  or  $z2$  shall be determined by first selecting randomly an interval within which it lies and then selecting the precise value from a distribution that is uniform over the interval selected.

804.4.4.2.6.3.2.2 The intervals within which the vertical rates lie shall depend on whether the aircraft is level, i.e. marked "L" in 804.4.4.2.6.2.3.1, or transitioning, i.e. marked "T" in 804.4.4.2.6.2.3.1, and shall be as follows:

<i>L</i>	<i>T</i>
[240 ft/min, 400 ft/min]	[3 200 ft/min, 6 000 ft/min]
[80 ft/min, 240 ft/min]	[400 ft/min, 3 200 ft/min]
[-80 ft/min, 80 ft/min]	[-400 ft/min, 400 ft/min]
[-240 ft/min, -80 ft/min]	[-3 200 ft/min, -400 ft/min]
[-400 ft/min, -240 ft/min]	[-6 000 ft/min, -3 200 ft/min]

804.4.4.2.6.3.2.3 For aircraft that are level over the entire encounter window, the vertical rate shall be  $z$  constant. The probabilities for the intervals within which  $z$  lies shall be as follows:

$\dot{z}$ (ft/min)	$prob(\dot{z})$
[240 ft/min, 400 ft/min]	0.0382
[80 ft/min, 240 ft/min]	0.0989
[-80 ft/min, 80 ft/min]	0.7040
[-240 ft/min, -80 ft/min]	0.1198
[-400 ft/min, -240 ft/min]	0.0391

804.4.4.2.6.3.2.4 Aircraft that are not level over the entire encounter window, the intervals for and  $z1$  shall be determined jointly by random selection using joint probabilities that depend on altitude layer and  $z2$  on whether the aircraft is transitioning at the beginning of the encounter window (Rate-to-Level), at the

end of the encounter window (Level-to-Rate) or at both the beginning and the end (Rate-to-Rate). The joint probabilities for the vertical rate intervals shall be a follows:

for aircraft with Rate-to-Level trajectories in layers 1 to 3,

$\dot{z}_2$ interval	joint probability of $\dot{z}_1$ and $\dot{z}_2$ intervals				
[240 ft/min, 400 ft/min]	0.0019	0.0169	0.0131	0.1554	0.0000
[80 ft/min, 240 ft/min]	0.0000	0.0187	0.0019	0.1086	0.0000
[-80 ft/min, 80 ft/min]	0.0037	0.1684	0.0094	0.1124	0.0075
[-240 ft/min, -80 ft/min]	0.0037	0.1461	0.0094	0.0243	0.0037
[-400 ft/min, -240 ft/min]	0.0000	0.1742	0.0094	0.0094	0.0019

-6 000 ft/min   -3 200 ft/min   -400 ft/min   400 ft/min   3 200 ft/min   6 000 ft/min    $\dot{z}_1$

For aircraft with Rate-to-Level trajectories in layers 4 to 6,

$\dot{z}_2$ interval	joint probability of $\dot{z}_1$ and $\dot{z}_2$ intervals				
[240 ft/min, 400 ft/min]	0.0105	0.0035	0.0000	0.1010	0.0105
[80 ft/min, 240 ft/min]	0.0035	0.0418	0.0035	0.1776	0.0279
[-80 ft/min, 80 ft/min]	0.0279	0.1219	0.0000	0.2403	0.0139
[-240 ft/min, -80 ft/min]	0.0035	0.0767	0.0000	0.0488	0.0105
[-400 ft/min, -240 ft/min]	0.0105	0.0453	0.0035	0.0174	0.0000

-6 000 ft/min   -3 200 ft/min   -400 ft/min   400 ft/min   3 200 ft/min   6 000 ft/min    $\dot{z}_1$

For aircraft with Level-to-Rate trajectories in layers 1 to 3,

$\dot{z}_2$ interval	joint probability of $\dot{z}_1$ and $\dot{z}_2$ intervals				
[3 200 ft/min, 6 000 ft/min]	0.0000	0.0000	0.0000	0.0000	0.0000
[400 ft/min, 3 200 ft/min]	0.0074	0.0273	0.0645	0.0720	0.1538
[-400 ft/min, 400 ft/min]	0.0000	0.0000	0.0000	0.0000	0.0000
[-3 200 ft/min, -400 ft/min]	0.2978	0.2084	0.1365	0.0273	0.0050
[-6 000 ft/min, -3 200 ft/min]	0.0000	0.0000	0.0000	0.0000	0.0000

-400 ft/min   -240 ft/min   -80 ft/min   80 ft/min   240 ft/min   400 ft/min    $\dot{z}_1$

For aircraft with Level-to-Rate trajectories in layers 4 to 6,

$\dot{z}_2$ interval	joint probability of $\dot{z}_1$ and $\dot{z}_2$ intervals					
[3 200 ft/min, 6 000 ft/min]	0.0000	0.0000	0.0000	0.0000	0.0000	
[400 ft/min, 3 200 ft/min]	0.0000	0.0000	0.0962	0.0577	0.1154	
[-400 ft/min, 400 ft/min]	0.0000	0.0000	0.0000	0.0000	0.0000	
[-3 200 ft/min, -400 ft/min]	0.1346	0.2692	0.2308	0.0577	0.0192	
[-6 000 ft/min, -3 200 ft/min]	0.0000	0.0000	0.0000	0.0000	0.0000	
	-400 ft/min	-240 ft/min	-80 ft/min	80 ft/min	240 ft/min	400 ft/min
	$\dot{z}_1$					

For aircraft with Rate-to-Rate trajectories in layers 1 to 3,

$\dot{z}_2$ interval	joint probability of $\dot{z}_1$ and $\dot{z}_2$ intervals					
[3 200 ft/min, 6 000 ft/min]	0.0000	0.0000	0.0007	0.0095	0.0018	
[400 ft/min, 3 200 ft/min]	0.0000	0.0018	0.0249	0.2882	0.0066	
[-400 ft/min, 400 ft/min]	0.0000	0.0000	0.0000	0.0000	0.0000	
[-3 200 ft/min, -400 ft/min]	0.0048	0.5970	0.0600	0.0029	0.0011	
[-6 000 ft/min, -3 200 ft/min]	0.0000	0.0007	0.0000	0.0000	0.0000	
	-6 000 ft/min	-3 200 ft/min	-400 ft/min	400 ft/min	3 200 ft/min	6 000 ft/min
	$\dot{z}_1$					

For aircraft with Rate-to-Rate trajectories in layers 4 to 6,

$\dot{z}_2$ interval	joint probability of $\dot{z}_1$ and $\dot{z}_2$ intervals					
[3 200 ft/min, 6 000 ft/min]	0.0014	0.0000	0.0028	0.0110	0.0069	
[400 ft/min, 3 200 ft/min]	0.0028	0.0028	0.0179	0.4889	0.0523	
[-400 ft/min, 400 ft/min]	0.0000	0.0000	0.0000	0.0000	0.0000	
[-3 200 ft/min, -400 ft/min]	0.0317	0.3029	0.0262	0.0152	0.0028	
[-6 000 ft/min, -3 200 ft/min]	0.0110	0.0220	0.0014	0.0000	0.0000	
	-6 000 ft/min	-3 200 ft/min	-400 ft/min	400 ft/min	3 200 ft/min	6 000 ft/min
	$\dot{z}_1$					

804.4.4.2.6.3.2.5 For a Rate-to-Rate track,  $|z_1 - z_2| < 566$  ft/min then the track shall be constructed with a constant rate equal to  $z_1$

804.4.4.2.6.3.3 Vertical acceleration

804.4.4.2.6.3.3.1 Subject to 804.4.4.2.6.3.2.5, for aircraft that are not level over the entire encounter window, the rate shall be constant and equal to  $z_1$  over at least the interval  $[t_{ca} - 40$  s,  $t_{ca} - 35$  s] at the beginning of the encounter window, and shall be constant and equal to  $z_2$  over at least the interval  $[t_{ca} + 5$  s,  $t_{ca} + 10$  s] at the end of the encounter window. The vertical acceleration shall be constant in the intervening period.

804.4.4.2.6.3.3.2 The vertical acceleration ( ) shall be modelled as follows:

$$\ddot{z} = A(\dot{z}_2 - \dot{z}_1) + \epsilon$$

where the parameter A is case-dependent as follows:

<i>Case</i>	<i>A (s<sup>-1</sup>)</i>	
	<i>Layers 1-3</i>	<i>Layers 4-6</i>
Rate-to-Level	0.071	0.059
Level-to-Rate	0.089	0.075
Rate-to-Rate	0.083	0.072

and the error  $\epsilon$  is selected randomly using the following probability density:

$$p(\epsilon) = \frac{1}{2\mu} \exp\left(-\frac{|\epsilon|}{\mu}\right)$$

where  $\mu = 0.3 \text{ ft s}^{-2}$ .

804.4.4.2.6.3.4 Acceleration start time. The acceleration start time shall be distributed uniformly in the time interval  $[tca - 35 \text{ s}, tca - 5 \text{ s}]$  and shall be such that  $z_2$  is achieved no later than  $tca + 5 \text{ s}$ .

#### 804.4.4.2.6.4 CHARACTERISTICS OF THE AIRCRAFT TRAJECTORIES IN THE HORIZONTAL PLANE

##### 804.4.4.2.6.4.1 Horizontal miss distance

804.4.4.2.6.4.1.1 For calculations of the effect of ACAS on the risk of collision (804.4.4.3), hmd shall be uniformly distributed in the range  $[0, 500 \text{ ft}]$ .

804.4.4.2.6.4.1.2 For calculations concerning the compatibility of ACAS with ATM (804.4.4.4), hmd shall be distributed so that the values of hmd have the following cumulative probabilities:

<i>hmd (ft)</i>	<i>cumulative probability</i>		<i>hmd (ft)</i>	<i>cumulative probability</i>	
	<i>Layers 1-3</i>	<i>Layers 4-6</i>		<i>Layers 1-3</i>	<i>Layers 4-6</i>
0	0.000	0.000	17013	0.999	0.868
1215	0.152	0.125	18228	1.000	0.897
2430	0.306	0.195	19443		0.916
3646	0.482	0.260	20659		0.927
4860	0.631	0.322	21874		0.939
6076	0.754	0.398	23089		0.946
7921	0.859	0.469	24304		0.952
8506	0.919	0.558	25520		0.965
9722	0.954	0.624	26735		0.983
10937	0.972	0.692	27950		0.993
12152	0.982	0.753	29165		0.996
13367	0.993	0.801	30381		0.999
14582	0.998	0.821	31596		1.000
15798	0.999	0.848			

804.4.4.2.6.4.2 Approach angle. The cumulative distribution for the horizontal approach angle shall be as follows:

<i>approach angle (deg.)</i>	<i>cumulative probability</i>		<i>approach angle (deg.)</i>	<i>cumulative probability</i>	
	<i>Layers 1-3</i>	<i>Layers 4-6</i>		<i>Layers 1-3</i>	<i>Layers 4-6</i>
0	0.00	0.00	100	0.38	0.28
10	0.14	0.05	110	0.43	0.31
20	0.17	0.06	120	0.49	0.35
30	0.18	0.08	130	0.55	0.43
40	0.19	0.08	140	0.62	0.50
50	0.21	0.10	150	0.71	0.59
60	0.23	0.13	160	0.79	0.66
70	0.25	0.14	170	0.88	0.79
80	0.28	0.19	180	1.00	1.00
90	0.32	0.22			

804.4.4.2.6.4.3 Aircraft speed. The cumulative distribution for each aircraft's horizontal ground speed at closest approach shall be as follows:

<i>ground speed (kt)</i>	<i>cumulative probability</i>		<i>ground speed (kt)</i>	<i>cumulative probability</i>	
	<i>Layers 1-3</i>	<i>Layers 4-6</i>		<i>Layers 1-3</i>	<i>Layers 4-6</i>
45	0.000		325	0.977	0.528
50	0.005		350	0.988	0.602
75	0.024	0.000	375	0.997	0.692
100	0.139	0.005	400	0.998	0.813
125	0.314	0.034	425	0.999	0.883
150	0.486	0.064	450	1.000	0.940
175	0.616	0.116	475		0.972
200	0.700	0.171	500		0.987
225	0.758	0.211	525		0.993
250	0.821	0.294	550		0.998
275	0.895	0.361	575		0.999
300	0.949	0.427	600		1.000

804.4.4.2.6.4.4 Horizontal manoeuvre probabilities. For each aircraft in each encounter, the probability of a turn, the Probability of a speed change given a turn, and the probability of a speed change given no turn shall be as follows:

Layer	Prob(turn)	Prob(speed change) given a turn	Prob(speed change) given no turn
1	0.31	0.20	0.50
2	0.29	0.20	0.25
3	0.22	0.10	0.15
4, 5, 6	0.16	0.05	0.10

804.4.4.2.6.4.4.1 Given a speed change, the probability of a speed increase shall be 0.5 and the probability of a speed decrease shall be 0.5.

804.4.4.2.6.4.5 Turn extent. The cumulative distribution for the extent of any turn shall be as follows:

Turn extent (deg.)	cumulative probability	
	Layers 1-3	Layers 4-6
15	0.00	0.00
30	0.43	0.58
60	0.75	0.90
90	0.88	0.97
120	0.95	0.99
150	0.98	1.00
180	0.99	
210	1.00	

804.4.4.2.6.4.5.1 The direction of the turn shall be random, with the probability of a left turn being 0.5 and the probability of a right turn being 0.5.

804.4.4.2.6.4.6 Bank angle. An aircraft's bank angle during a turn shall not be less than 15 degrees. The probability that it equals 15 degrees shall be 0.79 in layers 1-3 and 0.54 in layers 4-5. The cumulative distribution for larger bank angles shall be as follows:

Bank angle (deg.)	cumulative probability	
	Layers 1-3	Layers 4-6
15	0.79	0.54
25	0.96	0.82
35	0.99	0.98
50	1.00	1.00

804.4.4.2.6.4.7 Turn end time. The cumulative distribution for each aircraft's turn end time shall be as follows:

Turn end time (seconds before tca)	cumulative probability	
	Layers 1-3	Layers 4-6
0	0.42	0.28
5	0.64	0.65
10	0.77	0.76
15	0.86	0.85
20	0.92	0.94
25	0.98	0.99
30	1.00	1.00

804.4.4.2.6.4.8 Speed change. A constant acceleration or deceleration shall be randomly selected for each aircraft performing a speed change in a given encounter, and shall be applied for the duration of the encounter. Accelerations shall be uniformly distributed between 2 kt/s and 6 kt/s. Decelerations shall be uniformly distributed between 1 kt/s and 3 kt/s.

804.4.4.2.7 ACAS EQUIPAGE OF THE INTRUDER

The performance requirements specified in 804.4.4.3 and 804.4.4.4 each apply to three distinct situations in which the following conditions concerning the intruder's ACAS and trajectory shall apply:

- a) Where the intruder involved in each encounter is not equipped (804.4.4.2.1 j) 1)), it follows a trajectory identical to that which it follows when own aircraft is not equipped;
- b) Where the intruder is ACAS-equipped but follows a trajectory identical to that in the unequipped encounter (804.4.4.2.1 j) 2)):
  - 1) it follows the identical trajectory regardless of whether or not there is an RA;



- 2) the intruder ACAS generates an RA and transmits an RAC that is received immediately after any RA is first announced to the pilot of own aircraft;
  - 3) the sense of the RAC generated by the intruder ACAS and transmitted to own aircraft is opposite to the sense of the first RAC selected and transmitted to the intruder by own aircraft (804.4.3.6.1.3);
  - 4) the RAC transmitted by the intruder is received by own aircraft; and
  - 5) the requirements apply both when own aircraft has the lower aircraft address and when the intruder aircraft has the lower aircraft address; and
- c) Where the intruder is equipped with an ACAS having a collision avoidance logic identical to that of own ACAS (804.4.4.2.1 j) 3):
- 1) the conditions relating to the performance of own aircraft, ACAS and pilot apply equally to the intruder aircraft, ACAS and pilot;
  - 2) RACs transmitted by one aircraft are received by the other; and
  - 3) the requirements apply both when own aircraft has the lower aircraft address and when the intruder aircraft has the lower aircraft address.

804.4.4.2.8 **COMPATIBILITY BETWEEN DIFFERENT COLLISION AVOIDANCE LOGIC DESIGNS**  
When considering alternative collision avoidance logic designs, certification authorities should verify that:

- a) The performances of the alternative design are acceptable in encounters involving ACAS units that use existing designs; and
- b) The performances of the existing designs are not degraded by the use of the alternative design.

#### **804.4.4.3 Reduction in the risk of collision**

Under the conditions of 804.4.4.2, the collision avoidance logic shall be such that the expected number of collisions is reduced to the following proportions of the number expected in the absence of ACAS:

- a) When the intruder is not ACAS equipped 0.18;
- b) When the intruder is equipped but does not respond 0.32; and
- c) When the intruder is equipped and responds 0.04.

#### **804.4.4.4 Compatibility with air traffic management (ATM)**

##### 804.4.4.4.1 NUISANCE ALERT RATE

804.4.4.4.1.1 Under the conditions of 804.4.4.2, the collision avoidance logic shall be such that the proportion of RAs which are a “nuisance” (804.4.4.4.1.2) shall not exceed:

6% when own aircraft’s vertical rate at the time the RA is first issued is less than 400 ft/min; or  
8% when own aircraft’s vertical rate at the time the RA is first issued exceeds 400 ft/min.

804.4.4.4.1.2 An RA shall be considered a “nuisance” for the purposes of 804.4.4.4.1.1 unless, at some point in the encounter in the absence of ACAS, the horizontal separation and the vertical separation are simultaneously less than the following values:

	horizontal separation	vertical separation
above FL100	2.0 NM	750 ft
below FL100	1.2 NM	750 ft

804.4.4.4.2 COMPATIBLE SENSE SELECTION

804.4.4.4.2.1 Under the conditions of 804.4.4.2, the collision avoidance logic shall be such that the proportion of encounters in which following the RA results in an altitude separation at closest approach with the opposite sign to that occurring in the absence of ACAS shall not exceed the following values:

- a) When the intruder is not ACAS equipped 8%;
- b) When the intruder is equipped but does not respond 8%; and
- c) When the intruder is equipped and responds 12%.

804.4.4.4.3 DEVIATIONS CAUSED BY ACAS

804.4.4.4.3.1 Under the conditions of 804.4.4.2, the collision avoidance logic shall be such that the number of RAs resulting in “deviations” (804.4.4.4.3.2) greater than the values indicated shall not exceed the following proportions of the total number of RAs:

	<i>when own aircraft's vertical rate at the time the RA is first issued</i>	
	<i>is less than 400 ft/min</i>	<i>exceeds 400 ft/min</i>
<i>when the intruder is not ACAS equipped,</i>		
<i>for deviations <math>\geq 300</math> ft</i>	15%	23%
<i>for deviations <math>\geq 600</math> ft</i>	4%	13%
<i>for deviations <math>\geq 1\ 000</math> ft</i>	1%	7%
<i>when the intruder is equipped but does not respond,</i>		
<i>for deviations <math>\geq 300</math> ft</i>	23%	35%
<i>for deviations <math>\geq 600</math> ft</i>	6%	16%
<i>for deviations <math>\geq 1\ 000</math> ft</i>	2%	7%
<i>when the intruder is equipped and responds,</i>		
<i>for deviations <math>\geq 300</math> ft</i>	11%	23%
<i>for deviations <math>\geq 600</math> ft</i>	2%	12%
<i>for deviations <math>\geq 1\ 000</math> ft</i>	1%	6%

804.4.4.4.3.2 For the purposes of 804.4.4.3.1, the “deviation” of the equipped aircraft from the original trajectory shall be measured in the interval from the time at which the RA is first issued until the time at which, following cancellation of the RA, the equipped aircraft has recovered its original altitude rate. The deviation shall be calculated as the largest altitude difference at any time in this interval between the trajectory followed by the equipped aircraft when responding to its RA and its original trajectory.

#### **804.4.4.5 Relative value of conflicting objectives**

The collision avoidance logic should be such as to reduce as much as practicable the risk of collision (measured as defined in 804.4.4.3) and limit as much as practicable the disruption to ATM (measured as defined in 804.4.4.4).

### **804.4.5 ACAS USE OF EXTENDED SQUITTER REPORTS**

#### **804.4.5.1 ACAS hybrid surveillance using extended squitter position data**

##### 804.4.5.1.1 DEFINITIONS

**Active surveillance.** The process of tracking an intruder by using the information gained from the replies to own aircraft’s interrogations.

**Active track.** A track formed by measurements gained by active interrogation.

**Hybrid surveillance.** The process of using active surveillance to validate and monitor other aircraft being tracked principally using passive surveillance in order to preserve ACAS independence.

**Initial acquisition.** The process of starting the formation of a new track upon receipt of a squitter from a Mode S aircraft for which there is no track by making an active interrogation.

**Initial validation.** The process of verifying the relative position of a new track using passive information by comparing it to the relative position obtained by active interrogation.

**Passive surveillance.** The process of tracking another aircraft without interrogating it, by using the other aircraft’s extended squitters. ACAS uses the information contained in passive tracks to monitor the need for active surveillance, but not for any other purpose.

**Passive track.** After initial acquisition, a track maintained without active interrogation, using information contained in extended squitters.

804.4.5.1.2 An ACAS equipped to receive extended squitter position reports for passive surveillance of nonthreatening intruders shall utilize this passive position information in the following manner.

##### 804.4.5.1.3 PASSIVE SURVEILLANCE

804.4.5.1.3.1 Initial validation. At initial acquisition of an aircraft reporting extended squitter information, ACAS shall determine the relative range and bearing as computed from the position of own aircraft and the intruder’s position as reported in the extended squitter. This derived range and bearing and the altitude reported in the squitter shall be compared to the range, bearing and altitude determined by active ACAS interrogation of the aircraft. Differences between the derived and measured range and bearing and the squitter and squitter and reply altitude shall be computed and used in tests to determine whether the extended squitter data is valid. If these tests are satisfied the passive position shall be considered to be

validated and the track shall be maintained on passive data. If any of the above tests fail, the track shall be declared an active track and no further use shall be made of the subsequent passive surveillance data received for this track.

804.4.5.1.3.2 The following tests should be used to validate the position reported in the extended squitter message:

| slant range difference | < 200 m; and  
| bearing difference | < 45 degrees; and  
| altitude difference | < 100 ft.

804.4.5.1.3.3 Supplementary Active Interrogations. In order to ensure that an intruder's track is updated at least as frequently as required in the absence of extended squitter data (804.4.3.7.1.2.2), each time a track is updated using squitter information the time at which an active interrogation would next be required shall be calculated. An active interrogation shall be made at that time if a further squitter has not been received before the interrogation is due.

804.4.5.1.4 Revalidation and monitoring. If the following condition is met for a track being updated using passive surveillance data:

- a)  $|a| < 10\,000$  ft and either;
- b)  $|a| < 3\,000$  ft or  $|a - 3\,000 \text{ ft}| / |\dot{a}| < 60$  s; or  $0 \leq a$
- c)  $r < 3$  NM or  $(r - 3 \text{ NM}) / |\dot{r}| < 60$  s;  $0 \leq r$

where:  $a$  = intruder altitude separation in ft  
 $\dot{a}$  = altitude rate estimate in ft/s  $0 \leq a$   
 $r$  = intruder slant range in NM  
 $\dot{r}$  = range rate estimate in NM/s  $0 \leq r$

an active interrogation shall be made every 10 seconds to continuously revalidate and monitor the extended squitter data for as long as the above condition is met. The tests required in 4.5.1.3.1 shall be performed for each active surveillance. If any of these test fail, the track shall be declared an active track.

804.4.5.1.5 Full Active Surveillance. If the following condition is met for a track being updated via passive surveillance data:

- a)  $|a| < 10\,000$  ft and both;
- b)  $|a| < 3\,000$  ft or  $|a - 3\,000 \text{ ft}| / |\dot{a}| < 60$  s; and  $0 \leq a$
- c)  $r < 3$  NM or  $(r - 3 \text{ NM}) / |\dot{r}| < 60$  s;  $0 \leq r$

where:  $a$  = intruder altitude separation in ft  
 $\dot{a}$  = altitude rate estimate in ft/s  $0 \leq a$   
 $r$  = intruder slant range in NM  
 $\dot{r}$  = range rate estimate in NM/s  $0 \leq r$

The aircraft shall be declared an active track and shall be updated on active range measurements once per second for as long as the above condition is met.

#### 804.4.5.2 ACAS operation with an improved receiver MTL

- 804.4.5.2.1 An ACAS operating with a receiver having a MTL more sensitive than  $-74$  dBm shall implement the capabilities specified in the following paragraphs.
- 804.4.5.2.2 Dual minimum triggering levels. The ACAS receiver shall be capable of setting an indication for each squitter reception as to whether the reply would have been detected by an ACAS operating with a conventional MTL ( $-74$  dBm). Squitter receptions received at the conventional MTL shall be passed to the ACAS surveillance function for further processing. Squitter receptions that do not meet this condition shall be not be passed to the ACAS surveillance function.
- 804.4.5.2.3 Dual or re-triggerable reply processor. The ACAS Mode S reply processing function shall:
- a) Use separate reply processors for Mode S reply formats received at or above the conventional MTL and a separate reply processor for Mode S reply formats received below the conventional MTL; or,
  - b) Use a Mode S reply processor that will re-trigger if it detects a Mode S preamble that stronger than the reply that is currently being processed.